

Service Facts

UD2-9V-SF-1C



X340989P17

Gas Furnace — Variable Speed — 2 Stage Heat

Models: * - First letter may be "A" or "T"

*UD2B060A9V3VB	*UD2C100A9V5VB	*DD2B060A9V3VA
*UD2B080A9V3VB	*UD2C100B9V5VB	*DD2B080A9V3VA
*UD2C080A9V4VB	*UD2D120A9V5VB	*DD2C100A9V5VA
*UD2C080B9V4VB	*UD2D120B9V5VB	*DD2D120A9V5VA
*UD2B100A9V3VB	*UD2D140A9V5VB	

IMPORTANT — This document contains a wiring diagram and service information. This is customer property and is to remain with this unit. Please return to service information pack upon completion of work.

⚠ WARNING DISCONNECT POWER BEFORE SERVICING

Product Specifications ^①

MODEL	*UD2B060A9V3VB	*UD2B080A9V3VB	*UD2C080A9V4VB
TYPE	Upflow / Horizontal	Upflow / Horizontal	Upflow / Horizontal
RATINGS ^②			
1st Stage Input BTUH	39,000	52,000	52,000
1st Stage Capacity BTUH (ICS) ^③	31,200	41,600	41,600
2nd Stage Input BTUH	60,000	80,000	80,000
2nd Stage Capacity BTUH (ICS) ^③	48,000	64,000	64,000
Temp. rise (Min.-Max.) °F	30 - 60	30 - 60	30 - 60
BLOWER DRIVE	Direct	Direct	Direct
Diameter - Width (In.)	10 x 7	10 x 7	10 x 10
No. Used	1	1	1
Speeds (No.)	Variable	Variable	Variable
CFM vs. in. w.g.	See Airflow Table	See Airflow Table	See Airflow Table
Motor HP	1/2	1/2	3/4
R.P.M.	Variable	Variable	Variable
Volts / Ph / Hz	115/1/60	115/1/60	115/1/60
COMBUSTION FAN — Type	Centrifugal	Centrifugal	Centrifugal
Drive - No. Speeds	Direct - 2	Direct - 2	Direct - 2
Motor HP - RPM	1/100 - 2543/1727	1/100 - 2543/1727	1/100 - 2543/1727
Volts / Ph / Hz	115/1/60	115/1/60	115/1/60
FLA	0.70/0.40	0.70/0.40	0.70/0.40
FILTER — Furnished?	Yes	Yes	Yes
Type Recommended	High Velocity	High Velocity	High Velocity
Hi Vel. (No. - Size - Thk.)	1 - 17x25 - 1in.	1 - 17x25 - 1in.	1 - 20x25 - 1in.
VENT — Size (In.)	4 Round	4 Round	4 Round
HEAT EXCHANGER			
Type - Fired	Alum. Steel - Type 1	Alum. Steel - Type 1	Alum. Steel - Type 1
-Unfired			
Gauge (Fired)	20	20	20
ORIFICES — Main			
Nat. Gas Qty. — Drill Size	3 — 45	4 — 45	4 — 45
L.P. Gas Qty. — Drill Size	3 — 56	4 — 56	4 — 56
GAS VALVE	Redundant - Two Stage	Redundant - Two Stage	Redundant - Two Stage
PILOT SAFETY DEVICE			
Type	Hot Surface Ignition	Hot Surface Ignition	Hot Surface Ignition
BURNERS — Type	Multi-port In-shot	Multi-port In-shot	Multi-port In-shot
Number	3	4	4
POWER CONN. — V / Ph / Hz ^④	115/1/60	115/1/60	115/1/60
Ampacity (In Amps)	10.5	10.5	12.9
Max. Overcurrent Protection (Amps)	15	15	20
PIPE CONN. SIZE (In.)	1/2	1/2	1/2
DIMENSIONS			
Crated (In.)	H x W x D 41-3/4 x 19-1/2 x 30-1/2	H x W x D 41-3/4 x 19-1/2 x 30-1/2	H x W x D 41-3/4 x 23 x 30-1/2
WEIGHT			
Shipping (Lbs.) / Net (Lbs.)	136 / 126	142 / 132	166 / 155

① Central Furnace heating designs are certified to ANSI Z21.47 / CSA 2.3.

② For U.S. applications, above input ratings (BTUH) are up to 2,000 feet, derate 4% per 1,000 feet for elevations above 2,000 feet above sea level.

For Canadian applications, above input ratings (BTUH) are up to 4,500 feet, derate 4% per 1,000 feet for elevations above 4,500 feet above sea level.

③ Based on U.S. government standard tests.

④ The above wiring specifications are in accordance with National Electrical Code; however, installations must comply with local codes.

NOTICE: Since the manufacturer has a policy of continuous product and product data improvement, it reserves the right to change design and specifications without notice.

Service Facts

Product Specifications ^①

MODEL	*UD2C080B9V4VB	*UD2B100A9V3VB	*UD2C100A9V5VB
TYPE	Upflow/Horizontal	Upflow/Horizontal	Upflow/Horizontal
RATINGS ^②			
1st Stage Input BTUH	52,000	65,000	65,000
1st Stage Capacity BTUH (ICS) ^③	41,600	52,000	52,000
2nd Stage Input BTUH	80,000	100,000	100,000
2nd Stage Capacity BTUH (ICS) ^③	64,000	80,000	79,000
Temp. rise (Min.-Max.) °F.	30 - 60	40 - 70	35 - 65
BLOWER DRIVE			
Diameter - Width (In.)	Direct 10 x 10	Direct 10 x 7	Direct 10 x 10
No. Used	1	1	1
Speeds (No.)	Variable	Variable	Variable
CFM vs. in. w.g.	See Airflow Table	See Airflow Table	See Airflow Table
Motor HP	3/4	1/2	1
R.P.M.	Variable	Variable	Variable
Volts/Ph/Hz	115/1/60	115/1/60	115/1/60
COMBUSTION FAN — Type			
Drive - No. Speeds	Centrifugal Direct - 2	Centrifugal Direct - 2	Centrifugal Direct - 2
Motor HP - RPM	1/100 - 2543/1727	1/75 - 2708/1868	1/75 - 2708/1868
Volts/Ph/Hz	115/1/60	115/1/60	115/1/60
FLA	0.70/0.40	0.87/0.49	0.87/0.49
FILTER — Furnished?			
Type Recommended	Yes High Velocity	Yes High Velocity	Yes High Velocity
Hi Vel. (No.-Size-Thk.)	1 - 20x25 - 1in.	1 - 17x25 - 1in.	1 - 20x25 - 1in.
VENT — Size (In.)			
	4 Round	4 Round	4 Round
HEAT EXCHANGER			
Type -Fired	Alum. Steel - Type 1	Alum. Steel - Type 1	Alum. Steel - Type 1
-Unfired			
Gauge (Fired)	20	20	20
ORIFICES — Main			
Nat. Gas. Qty. — Drill Size	4 — 45	5 — 45	5 — 45
L.P. Gas Qty. — Drill Size	4 — 56	5 — 56	5 — 56
GAS VALVE			
	Redundant - Two Stage	Redundant - Two Stage	Redundant - Two Stage
PILOT SAFETY DEVICE			
Type	Hot Surface Ignition	Hot Surface Ignition	Hot Surface Ignition
BURNERS — Type			
Number	Multi-port In-shot 4	Multi-port In-shot 5	Multi-port In-shot 5
POWER CONN. — V/Ph/Hz ^④			
Ampacity (In Amps)	115/1/60 12.9	115/1/60 10.8	115/1/60 14.9
Max. Overcurrent Protection (Amps)	20	15	20
PIPE CONN. SIZE (In.)			
	1/2	1/2	1/2
DIMENSIONS			
Crated (In.)	H x W x D 41-3/4 x 23 x 30-1/2	H x W x D 41-3/4 x 19-1/2 x 30-1/2	H x W x D 41-3/4 x 23 x 30-1/2
WEIGHT			
Shipping (Lbs.)/Net (Lbs.)	166 / 155	142 / 132	166 / 155

① Central Furnace heating designs are certified to ANSI Z21.47 / CSA 2.3.

② For U.S. applications, above input ratings (BTUH) are up to 2,000 feet, derate 4% per 1,000 feet for elevations above 2,000 feet above sea level.

For Canadian applications, above input ratings (BTUH) are up to 4,500 feet, derate 4% per 1,000 feet for elevations above 4,500 feet above sea level.

③ Based on U.S. government standard tests.

④ The above wiring specifications are in accordance with National Electrical Code; however, installations must comply with local codes.

Product Specifications ^①

MODEL	*UD2C100B9V5VB	*UD2D120A9V5VB	*UD2D120B9V5VB	*UD2D140A9V5VB
TYPE	Upflow / Horizontal	Upflow / Horizontal	Upflow / Horizontal	Upflow / Horizontal
RATINGS ^②				
1st Stage Input BTUH	65,000	78,000	78,000	91,000
1st Stage Capacity BTUH (ICS) ^③	52,000	62,400	62,400	72,800
2nd Stage Input BTUH	100,000	120,000	120,000	140,000
2nd Stage Capacity BTUH (ICS) ^③	79,000	97,000	97,000	111,000
Temp. rise (Min.-Max.) °F.	35 - 65	35 - 65	35 - 65	40 - 70
BLOWER DRIVE				
	Direct	Direct	Direct	Direct
Diameter - Width (In.)	10 x 10	10 x 10	10 x 10	10 x 10
No. Used	1	1	1	1
Speeds (No.)	Variable	Variable	Variable	Variable
CFM vs. in. w.g.	See Airflow Table	See Airflow Table	See Airflow Table	See Airflow Table
Motor HP	1	1	1	1
R. P.M.	Variable	Variable	Variable	Variable
Volts/Ph/Hz	115/1/60	115/1/60	115/1/60	115/1/60
COMBUSTION FAN — Type				
	Centrifugal	Centrifugal	Centrifugal	Centrifugal
Drive - No. Speeds	Direct - 2	Direct - 2	Direct - 2	Direct - 2
Motor HP - RPM	1/75 - 2708/1868	1/60 - 3090/2225	1/60 - 3090/2225	1/60 - 3100/2350
Volts/Ph/Hz	115/1/60	115/1/60	115/1/60	115/1/60
FLA	0.87/0.49	1.14/0.51	1.14/0.51	1.16/0.54
FILTER — Furnished?				
	Yes	Yes	Yes	Yes
Type Recommended	High Velocity	High Velocity	High Velocity	High Velocity
Hi Vel. (No.-Size-Thk.)	1 - 20x25 - 1in.	1 - 24x25 - 1in.	1 - 24x25 - 1in.	1 - 24x25 - 1in.
VENT — Size (In.)				
	4 Round	4 Round	4 Round	4 Round
HEAT EXCHANGER				
Type -Fired	Alum. Steel - Type 1	Alum. Steel - Type 1	Alum. Steel - Type 1	Alum. Steel - Type 1
-Unfired				
Gauge (Fired)	20	20	20	20
ORIFICES — Main				
Nat. Gas. Qty. — Drill Size	5 — 45	6 — 45	6 — 45	7 — 45
L. P. Gas Qty. — Drill Size	5 — 56	6 — 56	6 — 56	7 — 56
GAS VALVE				
	Redundant - Two Stage	Redundant - Two Stage	Redundant - Two Stage	Redundant - Two Stage
PILOT SAFETY DEVICE				
Type	Hot Surface Ignition	Hot Surface Ignition	Hot Surface Ignition	Hot Surface Ignition
BURNERS — Type				
	Multi-port In-shot	Multi-port In-shot	Multi-port In-shot	Multi-port In-shot
Number	5	6	6	7
POWER CONN. — V/Ph/Hz ^④				
	115/1/60	115/1/60	115/1/60	115/1/60
Ampacity (In Amps)	14.9	15.3	15.3	15.3
Max. Overcurrent Protection (Amps)	20	20	20	20
PIPE CONN. SIZE (In.)				
	1/2	1/2	1/2	1/2
DIMENSIONS				
	H x W x D	H x W x D	H x W x D	H x W x D
Crated (In.)	41-3/4 x 23 x 30-1/2	41-3/4 x 26-1/2 x 30-1/2	41-3/4 x 26-1/2 x 30-1/2	41-3/4 x 26-1/2 x 30-1/2
WEIGHT				
Shipping (Lbs.)/Net (Lbs.)	166 / 155	193 / 181	193 / 181	197 / 185

Service Facts

Product Specifications ^①

MODEL	*DD2B060A9V3VA	*DD2B080A9V3VA	*DD2C100A9V5VA	DD2D120A9V5VA
TYPE	Downflow / Horizontal	Downflow / Horizontal	Downflow / Horizontal	Downflow / Horizontal
RATINGS ^②				
1st Stage Input BTUH	39,000	52,000	65,000	78,000
1st Stage Capacity BTUH (ICS) ^③	31,200	41,600	52,000	62,400
2nd Stage Input BTUH	60,000	80,000	100,000	120,000
2nd Stage Capacity BTUH (ICS) ^③	48,000	63,000	81,000	95,000
Temp. rise (Min.-Max.) °F.	35 - 65	35 - 65	35 - 65	35 - 65
BLOWER DRIVE				
	Direct	Direct	Direct	Direct
Diameter - Width (In.)	10 x 7	10 x 7	11 x 10	11 x 10
No. Used	1	1	1	1
Speeds (No.)	Variable	Variable	Variable	Variable
CFM vs. in. w.g.	See Airflow Table	See Airflow Table	See Airflow Table	See Airflow Table
Motor HP	1/2	1/2	1	1
R.P.M.	Variable	Variable	Variable	Variable
Volts/Ph/Hz	115/1/60	115/1/60	115/1/60	115/1/60
COMBUSTION FAN — Type				
	Centrifugal	Centrifugal	Centrifugal	Centrifugal
Drive - No. Speeds	Direct - 2	Direct - 2	Direct - 2	Direct - 2
Motor HP - RPM	1/100 - 2543/1727	1/100 - 2543/1727	1/75 - 2708/1868	1/60 - 3090/2225
Volts/Ph/Hz	115/1/60	115/1/60	115/1/60	115/1/60
FLA	0.70/0.40	0.70/0.40	0.87/0.49	1.14/0.51
FILTER — Furnished?				
	Yes	Yes	Yes	Yes
Type Recommended	High Velocity	High Velocity	High Velocity	High Velocity
Hi Vel. (No.-Size-Thk.)	2 - 14x20 - 1in.	2 - 14x20 - 1in.	2 - 16x20 - 1in.	2 - 16x20 - 1in.
VENT — Size (In.)				
	4 Round	4 Round	4 Round	4 Round
HEAT EXCHANGER				
Type -Fired	Alum. Steel - Type 1	Alum. Steel - Type 1	Alum. Steel - Type 1	Alum. Steel - Type 1
-Unfired				
Gauge (Fired)	20	20	20	20
ORIFICES — Main				
Nat. Gas Qty. — Drill Size	3 — 45	4 — 45	5 — 45	6 — 45
L.P. Gas Qty. — Drill Size	3 — 56	4 — 56	5 — 56	6 — 56
GAS VALVE				
	Redundant - Two Stage	Redundant - Two Stage	Redundant - Two Stage	Redundant - Two Stage
PILOT SAFETY DEVICE				
Type	Hot Surface Ignition	Hot Surface Ignition	Hot Surface Ignition	Hot Surface Ignition
BURNERS — Type				
	Multi-port In-shot	Multi-port In-shot	Multi-port In-shot	Multi-port In-shot
Number	3	4	5	6
POWER CONN. — V/Ph/Hz ^④				
	115/1/60	115/1/60	115/1/60	115/1/60
Ampacity (In Amps)	10.5	10.5	14.9	15.3
Max. Overcurrent Protection (Amps)	15	15	20	20
PIPE CONN. SIZE (In.)				
	1/2	1/2	1/2	1/2
DIMENSIONS				
	H x W x D	H x W x D	H x W x D	H x W x D
Crated (In.)	41-3/4 x 19-1/2 x 30-1/2	41-3/4 x 19-1/2 x 30-1/2	41-3/4 x 23 x 30-1/2	41-3/4 x 26-1/2 x 30-1/2
WEIGHT				
Shipping (Lbs.)/Net (Lbs.)	140 / 129	146 / 135	166 / 155	197 / 185

① Central Furnace heating designs are certified to ANSI Z21.47 / CSA 2.3.

② For U.S. applications, above input ratings (BTUH) are up to 2,000 feet, derate 4% per 1,000 feet for elevations above 2,000 feet above sea level.

For Canadian applications, above input ratings (BTUH) are up to 4,500 feet, derate 4% per 1,000 feet for elevations above 4,500 feet above sea level.

③ Based on U.S. government standard tests.

④ The above wiring specifications are in accordance with National Electrical Code; however, installations must comply with local codes.

Safety Section

WARNING

CARBON MONOXIDE POISONING HAZARD

Failure to follow the steps outlined below for each appliance connected to the venting system being placed into operation could result in carbon monoxide poisoning or death.

The following steps shall be followed for each appliance connected to the venting system being placed into operation, while all other appliances connected to the venting system are not in operation:

1. Seal any unused openings in the venting system.
2. Inspect the venting system for proper size and horizontal pitch, as required in the National Fuel Gas Code, ANSI Z223.1/NFPA 54 or the CAN/CGA B149 Installation Codes and these instructions. Determine that there is no blockage or restriction, leakage, corrosion and other deficiencies which could cause an unsafe condition.
3. As far as practical, close all building doors and windows and all doors between the space in which the appliance(s) connected to the venting system are located and other deficiencies which could cause an unsafe condition.
4. Close fireplace dampers.
5. Turn on clothes dryers and any appliance not connected to the venting system. Turn on any exhaust fans, such as range hoods and bathroom exhausts, so they are operating at maximum speed. Do not operate a summer exhaust fan.
6. Follow the lighting instructions. Place the appliance being inspected into operation. Adjust the thermostat so appliance is operating continuously.
7. If improper venting is observed during any of the above tests, the venting system must be corrected in accordance with the National Fuel Gas Code, ANSI Z221.1/NFPA 54 and/or CAN/CGA B149 Installation Codes.
8. After it has been determined that each appliance connected to the venting system properly vents where tested as outlined above, return doors, windows, exhaust fans, fireplace dampers and any other gas-fired burning appliance to their previous conditions of use.

WARNING

The cabinet must have an uninterrupted or unbroken ground according to National Electrical Code, ANSI/NFPA 70 - "latest edition" and Canadian Electrical Code, CSA C22.1 or local codes to minimize personal injury if an electrical fault should occur. A failure to follow this warning could result in an electrical shock, fire, injury, or death.

WARNING

CARBON MONOXIDE POISONING HAZARD

Failure to follow the installation instructions for the venting system being placed into operation could result in carbon monoxide poisoning or death.

WARNING

FIRE OR EXPLOSION HAZARD

Failure to follow the safety warnings exactly could result in serious injury, death or property damage.

Never test for gas leaks with an open flame. Use a commercially available soap solution made specifically for the detection of leaks to check all connections. A fire or explosion may result causing property damage, personal injury, or loss of life.

WARNING

FIRE OR EXPLOSION HAZARD

Failure to follow the safety warnings exactly could result in serious injury, death or property damage.

Improper servicing could result in dangerous operation, serious injury, death, or property damage.

WARNING

BODILY INJURY CAN RESULT FROM HIGH VOLTAGE ELECTRICAL COMPONENTS, FAST MOVING FANS, AND COMBUSTIBLE GAS. FOR PROTECTION FROM THESE INHERENT HAZARDS DURING INSTALLATION AND SERVICING, THE ELECTRICAL SUPPLY MUST BE DISCONNECTED AND THE MAIN GAS VALVE MUST BE TURNED OFF. IF OPERATING CHECKS MUST BE PERFORMED WITH THE UNIT OPERATING, IT IS THE TECHNICIANS RESPONSIBILITY TO RECOGNIZE THESE HAZARDS AND PROCEED SAFELY.

CAUTION

THE INTEGRATED FURNACE CONTROL IS POLARITY SENSITIVE. THE HOT LEG OF THE 115 VAC POWER MUST BE CONNECTED TO THE BLACK FIELD LEAD.

Service Facts

Sequence Of Operation

Thermostat call for heat (2-stage thermostat)

Call for 1st stage only:

R and W1 thermostat contacts close signaling the control module to run its self-check routine. After the control module has verified that the 1st stage pressure switch contacts are open and the limit switch(es) contacts are closed, the draft blower will be energized.

As the induced draft blower comes up to speed, the pressure switch contacts will close and the ignitor warm up period will begin. The igniter will heat for approx. 17 seconds, then the gas valve is energized in 1st stage to permit gas flow to the burners. The flame sensor confirms that ignition has been achieved within the 4 second ignition trial period.

As the flame sensor confirms that ignition has been achieved, the delay to fan ON period begins timing and after approx. 45 seconds the indoor blower motor will be energized at low speed and will continue to run during the heating cycle.

Call for 2nd stage after 1st stage:

R and W2 thermostat contacts close signaling a call for 2nd stage heat. After a 30 second delay, the induced draft blower will be energized on high speed and the 2nd stage pressure switch contacts will close allowing the gas valve to be energized in 2nd stage and the indoor blower motor in high speed.

2nd stage satisfied, 1st stage still called:

R and W2 thermostat contacts open signaling that 2nd stage heating requirements are satisfied. The induced draft blower is reduced to low speed allowing the 2nd stage pressure switch contacts to open and the gas valve is reduced to 1st stage. After approx. 30 seconds the indoor blower motor is reduced to low speed.

1st stage satisfied:

R and W1 thermostat contacts open signaling that 1st stage heating requirements are satisfied. The gas valve will close and the induced draft blower will be de-energized. The indoor blower motor will continue to run for the heating fan off period (Field selectable at 90, 120, 150 or 180 seconds), then will be de-energized by the control module.

Thermostat call for heat (1-stage Thermostat)

R and W thermostat contacts close signaling a call for heat. 1st stage sequence of operation remains the same as above. 2nd stage delay will be reflective dip switch S7-1 and S7-2.

Reference the back of service facts for delay options.

Thermostat satisfied (1-stage Thermostat):

Contacts open signaling the control module to close the gas valve and de-energize the induced draft blower. The indoor blower motor will continue to operate at high heat speed for approx. 30 seconds after the flames are extinguished and then is switched to low heat speed for the remaining FAN-OFF period.

⚠ WARNING

Should overheating occur, or the gas supply fail to shut off, shut off the gas supply to the unit before shutting off the electrical supply. Failure to follow this warning could result in property damage, personal injury, or death.

Indoor Blower Timing

Heating: The ECM Fan Control controls the variable speed indoor blower. The blower "on" time is fixed at 45 seconds after ignition. The FAN-OFF period is field selectable by dip switches S7-3 and S7-4 on the Integrated Furnace Control at 90, 120, 150, or 180 seconds. The factory setting is 90 seconds (See unit wiring diagram).

Cooling: The fan delay-off period is set by dip switches on the ECM Fan Control board connected to the Integrated Furnace Control. The options for cooling delay off is field selectable by dip switches S4-1 and S4-2.

The following table and graph explain the delay-off settings:

COOLING OFF - DELAY OPTIONS

SWITCH SETTINGS		SELECTION	NOMINAL AIRFLOW
S4-1 - OFF	S4-2 - OFF	NONE	SAME
S4-1 - ON	S4-2 - OFF	1.5 MINUTES	100% *
S4-1 - OFF	S4-2 - ON	3 MINUTES	50%
S4-1 - ON	S4-2 - ON	**	50 - 100%

* - This setting is equivalent to BAY24X045 relay benefit

** - This selection provides **ENHANCED MODE**, which is a ramping up and ramping down of the blower speed to provide improved comfort, quietness, and potential energy savings. See Wiring Diagram notes on the unit or in the Service Facts for complete wiring setup for **ENHANCED MODE**. The graph which follows, shows the ramping process.

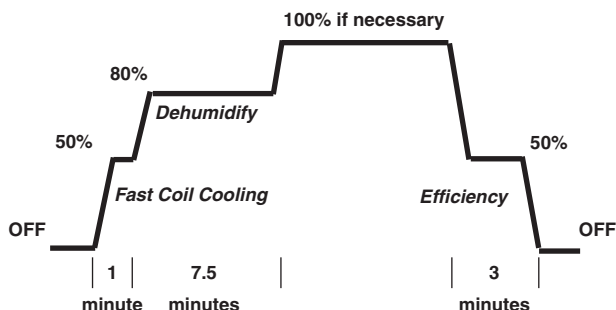

⚠ WARNING

BODILY INJURY CAN RESULT FROM HIGH VOLTAGE ELECTRICAL COMPONENTS, FAST MOVING FANS, AND COMBUSTIBLE GAS. FOR PROTECTION FROM THESE INHERENT HAZARDS DURING INSTALLATION AND SERVICING, THE ELECTRICAL SUPPLY MUST BE DISCONNECTED AND THE MAIN GAS VALVE MUST BE TURNED OFF. IF OPERATING CHECKS MUST BE PERFORMED WITH THE UNIT OPERATING, IT IS THE TECHNICIANS RESPONSIBILITY TO RECOGNIZE THESE HAZARDS AND PROCEED SAFELY.

⚠ CAUTION

THE INTEGRATED FURNACE CONTROL IS POLARITY SENSITIVE. THE HOT LEG OF THE 115 VAC POWER MUST BE CONNECTED TO THE BLACK FIELD LEAD.

Periodic Servicing Requirements

WARNING

Disconnect power to the unit before removing the blower door. Failure to follow this warning could result in personal injury from moving parts.

1. GENERAL INSPECTION – *Examine the furnace installation annually for the following items:*
 - a. All flue product carrying areas external to the furnace (i.e. chimney, vent connector) are clear and free of obstruction. A vent screen in the end of the vent (flue) pipe must be inspected for blockage annually.
 - b. The vent connector is in place, slopes upward and is physically sound without holes or excessive corrosion.
 - c. The return air duct connection(s) is physically sound, is sealed to the furnace and terminates outside the space containing the furnace.
 - d. The physical support of the furnace should be sound without sagging, cracks, gaps, etc., around the base so as to provide a seal between the support and the base.
 - e. There are no obvious signs of deterioration of the furnace.
2. FILTERS – Filters should be cleaned or replaced (with high velocity filters only), monthly and more frequently during high use times of the year such as midsummer or midwinter.
3. BLOWERS – The blower size and speed determine the air volume delivered by the furnace. The blower motor bearings are factory lubricated and under normal operating conditions do not require servicing. If motor lubrication is required it should only be done by a qualified servicer. Annual cleaning of the blower wheel and housing is recommended for maximum air output, and this must be performed only by a qualified servicer or service agency.
4. IGNITER – This unit has a special hot surface direct ignition device that automatically lights the burners. Please note that it is very fragile and should be handled with care.

CAUTION

Do not touch igniter. It is extremely hot.

5. BURNER – Gas burners do not normally require scheduled servicing, however, accumulation of foreign material may cause a yellowing flame or delayed ignition. Either condition indicates that a service call is required. For best operation, burners must be cleaned annually using brushes and vacuum cleaner.

Turn off gas and electric power supply. To clean burners, remove burner box cover (6 to 8 screws) and top burner bracket. Lift burners from orifices.

NOTE:

Be careful not to break igniter when removing burners.

Clean burners with brush and/or vacuum cleaner. Re-assemble parts by reversal of the above procedure. The burner box must be resealed when replacing box cover.

NOTE:

On LP (propane) units, some light yellow tipping of the outer mantle is normal. Inner mantle should be bright blue.

Natural gas units should not have any yellow tipped flames. This condition indicates that a service call is required. For best operation, burners must be cleaned annually using brushes and vacuum cleaner.

NOTE:

On LP (propane) units, due to variations in BTU content and altitude, servicing may be required at shorter intervals.

WARNING

CARBON MONOXIDE POISONING HAZARD

Failure to follow the service and/or periodic maintenance instructions for the furnace and venting system, could result in carbon monoxide poisoning or death.

6. HEAT EXCHANGER/FLUE PIPE – These items must be inspected for signs of corrosion, and/or deterioration at the beginning of each heating season by a qualified service technician and cleaned annually for best operation. To clean flue gas passages, follow recommendations below:
 - a. Turn off gas and electric power supply.
 - b. Inspect flue pipe exterior for cracks, leaks, holes or leaky joints. Some discoloration of PVC pipe is normal.
 - c. Remove burner compartment door from furnace.
 - d. Inspect around insulation covering flue collector box. Inspect induced draft blower connections from recuperative cell and to the flue pipe connection.
 - e. Remove burners. (See 4.)
 - f. Use a mirror and flashlight to inspect interior of heat exchanger, be careful not to damage the igniter, flame sensor or other components.
 - g. If any corrosion is present, contact a service agency. Heat exchanger should be cleaned by a qualified service technician.
 - h. After inspection is complete replace burner box cover, burners, and furnace door.
 - i. Restore gas supply. Check for leaks using a soap solution. Restore electrical supply. Check unit for normal operation.
7. COOLING COIL CONDENSATE DRAIN – If a cooling coil is installed with the furnace, condensate drains should be checked and cleaned periodically to assure that condensate can drain freely from coil to drain. If condensate cannot drain freely water damage could occur. (See Condensate Drain in Installer's Guide)

CAUTION

Label all wires prior to disconnection when servicing controls. Wiring errors can cause improper and dangerous operation.

Verify proper operation after servicing.

WARNING

NEVER USE AN OPEN FLAME TO TEST FOR GAS LEAKS. AN EXPLOSION COULD OCCUR, CAUSING INJURY OR DEATH.

Schematic Diagram

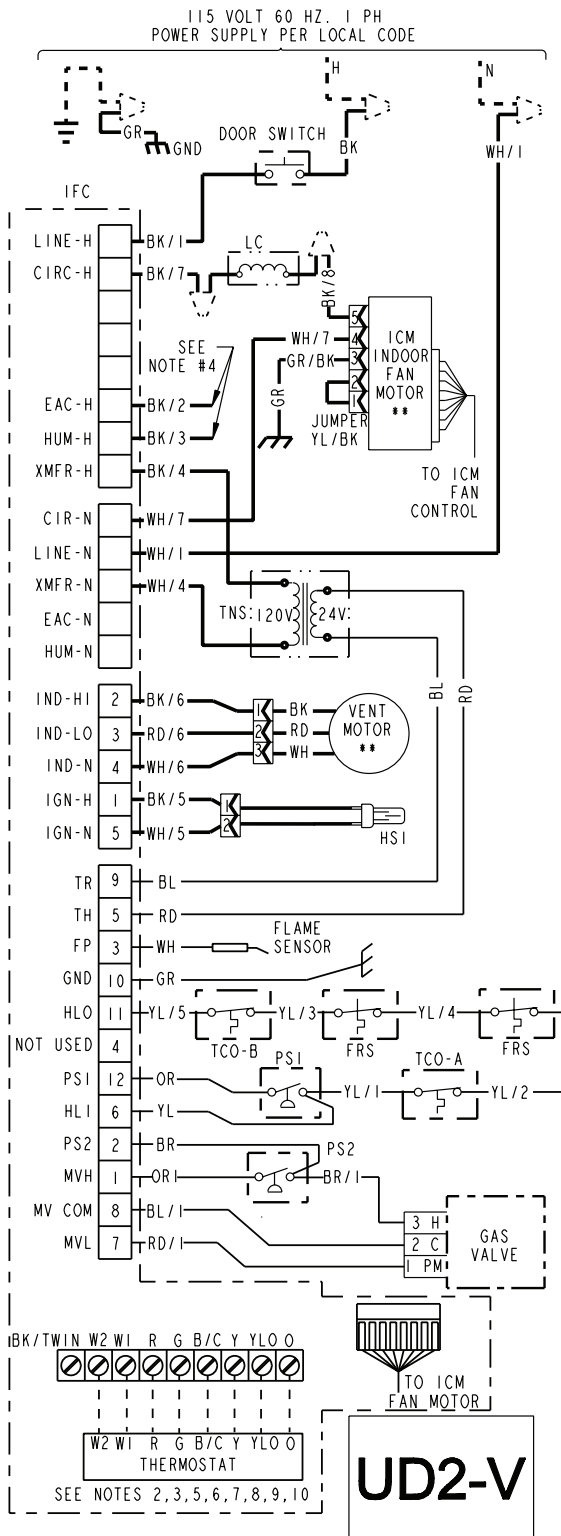
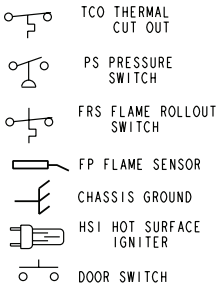

TABLE "A"	
MODELS	
•UD2B060A9V3V••	
•UD2B080A9V3V••	
•UD2C080A9V4V••	
•UD2C080B9V4V••	
•UD2B100A9V3V••	
•UD2C100A9V5V••	
•UD2C100B9V5V••	
•UD2D120A9V5V••	
•UD2D120B9V5V••	
•UD2D140A9V5V••	

* PREFIX MAY BE "A" OR "T"
 • SUFFIX MAY BE "A" THROUGH "Z"

INTEGRATED FURNACE CONTROL
 REPLACE WITH PART CNT06015 OR EQUIVALENT
ELECTRICAL RATING
 INPUT: 25 VAC, 60 HZ.
 XFMR SEC. CURRENT: 450 MA.
 MV 1ST STAGE OUTPUT: 1.5 A @ 24 VAC
 MV 2ND STAGE OUTPUT: 0.5 A @ 24 VAC
 IND OUTPUT: 2.2 FLA, 3.5 LRA @ 120 VAC
 CIRC. BLOWER OUTPUT: 14.5 FLA,
 25 LRA @ 120 VAC
 HUMIDIFIER & AIR CLEANER
 MAX. LOAD: 1.0 A @ 120 VAC
 IGNITER OUTPUT: 2.0 A @ 120 VAC
TIMINGS
 IGN WARMUP: 20 SEC.
 RETRIES: 2 RECYCLES: 10
 HEAT ON DELAY: 45 SEC.
 COOL ON DELAY: 2 SEC.



WARNING
 HAZARDOUS VOLTAGE:
 DISCONNECT ALL ELECTRICAL POWER INCLUDING REMOTE DISCONNECTS BEFORE SERVICING.
 FAILURE TO DISCONNECT POWER BEFORE SERVICING CAN CAUSE SEVERE PERSONAL INJURY OR DEATH.

CAUTION
 USE COPPER CONDUCTORS ONLY!
 UNIT TERMINALS ARE NOT DESIGNED TO ACCEPT OTHER TYPES OF CONDUCTORS.
 FAILURE TO DO SO MAY CAUSE DAMAGE TO THE EQUIPMENT.

DIAGNOSTIC CODES
 RED LED FLASH:
 1 FLASH : FLAME SENSED WHEN NO FLAME SHOULD BE PRESENT
 2 FLASHES: PRESSURE SWITCH STUCK CLOSED
 3 FLASHES: 1ST-STAGE PRESSURE SWITCH STUCK OPEN/ NOT CLOSING
 4 FLASHES: OPEN THERMAL LIMIT OR OPEN ROLLOUT
 5 FLASHES: OPEN LOW VOLTAGE FUSE
 6 FLASHES: 1ST STAGE PRESSURE SWITCH OPENED 5 TIMES WITHIN ONE CYCLE --1 HOUR LOCKOUT
 7 FLASHES: SYSTEM LOCKOUT (RETRY)
 8 FLASHES: SYSTEM LOCKOUT (RECYCLE)
 9 FLASHES: REVERSE POLARITY OR POOR GROUNDING
 10 FLASHES: GAS VALVE ENERGIZED WITH NO CALL FOR HEAT
 12 FLASHES: IGNITOR RELAY FAILURE INTERNAL IN BOARD. REPLACE "IFC"
 SOLID : GAS VALVE RELAY FAILURE INTERNAL IN BOARD. REPLACE "IFC"
 3 DOUBLE: 2ND STAGE PRESSURE SWITCH OPEN SYSTEM REVERTS TO 1ST STAGE HEAT
 AMBER LED FLASH:
 1 FLASH : 1ST STAGE CALL FOR HEAT
 2 FLASHES: 2ND STAGE CALL FOR HEAT
 3 FLASHES: W2 CALL PRESENT WITH NO W1
 4 FLASHES: Y PRESENT WITH NO G CALL
 RAPID : LOW FLAME SENSE CURRENT
 GREEN LED FLASH:
 1 FLASH: STANDBY MODE OF CALL FOR COOLING

WIRE COLOR	
BK	BLACK
WH	WHITE
YL	YELLOW
OR	ORANGE
GR	GREEN
BR	BROWN
RD	RED
BL	BLUE

WIRE COLOR	
L	LINE
N	NEUTRAL
GND	GROUND
B/C	COMMON
HLO	HIGH LIMIT OUTPUT
HLI	HIGH LIMIT INPUT
TR	24 VAC (COMMON)
MV	MAIN GAS VALVE
TNS	TRANSFORMER

- NOTES:**
- IF ANY OF THE ORIGINAL WIRING AS SUPPLIED WITH THIS FURNACE MUST BE REPLACED, IT MUST BE WITH WIRE HAVING A TEMPERATURE RATING OF AT LEAST 105 C.
 - THERMOSTAT HEAT ANTICIPATOR SETTING: FIRST STAGE .38 AMPS, SECOND STAGE .13 AMPS. IF SETTING IS NOT FIXED ON THERMOSTAT, FOR SINGLE STAGE HEATING THERMOSTAT SET AT .51 AMPS.
 - FOR PROPER OPERATION OF COOLING SPEED, "Y" TERMINAL MUST BE CONNECTED TO THE ROOM THERMOSTAT.
 - THESE LEADS PROVIDE 120V POWER CONNECTIONS FOR ELECTRONIC AIR CLEANER (EAC) AND HUMIDIFIER (HUM). MAX. LOAD: 1.0 AMPS EACH.
 - WHEN USING A SINGLE STAGE HEATING THERMOSTAT, THE 2ND STAGE HEAT DELAY IS CONTROLLED BY S7-1 & S7-2. REFERENCE THE SERVICE FACTS FOR DIP SWITCH CONFIGURATIONS.
 - GREEN LIGHT (CFM) FLASHES ONCE PER 100 CFM COMMAND.
 - FOR HEAT PUMP SYSTEMS Y AND O MUST BE CONNECTED TO THE LOW-VOLTAGE TERMINAL BOARD.
 - FOR TWO COMPRESSOR SYSTEMS: USE "YLO" FOR LOW SPEED AND "Y" FOR HIGH SPEED CONNECTION TO THE LOW-VOLTAGE TERMINAL BOARD. FOR TWO STEP SCROLL SYSTEM, USE "Y" FOR LOW SPEED AND "BK" FOR HIGH SPEED CONNECTIONS ON THE LOW VOLTAGE TERMINAL BOARD. PLACE A JUMPER BETWEEN "R" AND "O" AND MOVE "S5-2" TO THE "OFF" POSITION.
 - INTERNAL HUMIDISTAT IS TO BE CONNECTED BETWEEN "R" & "BK". **DO NOT CUT ANY JUMPERS ON THIS BOARD.** SWITCH "S5-2" MUST BE SET IN THE "OFF" POSITION IF HUMIDISTAT IS USED. THE "S5-2" SWITCH MUST ALSO BE TURNED TO "OFF" WHEN APPLYING AN AIRFLOW COMMAND SIGNAL TO "BK". THE "BK" TERMINAL MUST BE USED WHEN APPLYING A HUMIDISTAT. A 402 THERMOSTAT (WITH "BK" ENABLED), A TWO STEP SCROLL COMPRESSOR OR RESIDENTIAL ZONING SYSTEM.
 - A JUMPER MUST BE PLACED BETWEEN "R" & "O" TO ENABLE THE "BK" CIRCUIT OR ENHANCED MODE (COMFORT R). THIS "R" TO "O" JUMPER MUST BE IN PLACE FOR HUMIDISTAT DEHUMIDIFICATION AND PROPER BLOWER OPERATION WITH A TWO STEP SCROLL COMPRESSOR.
 - SEE INDOOR MOTOR AIRFLOW SELECTION CHART, LOCATED IN THE FURNACE FOR DIP SWITCH SETTINGS TO SET AIRFLOW AND COOLING OFF DELAYS.
 - POWER MUST BE OFF WHEN DIP SWITCHES ARE SET.
 - USED ON ALL DOWNFLOW VARIABLE SPEED MODELS EXCEPT FOR •DD2B060A9V3V•• AND •DD2B080A9V3V••.

Service Facts

Wiring Diagram

DIP SWITCHES			
W2 DELAY S7-1, S7-2	S7-1	S7-2	TIME
	OFF	OFF	OFF*
	ON	OFF	10 MINUTES
	OFF	ON	AUTO
HEAT OFF DELAY S7-3, S7-4	S7-3	S7-4	TIME
	OFF	OFF	90 SECS*
	ON	OFF	120 SECS
	ON	ON	150 SECS
HEAT PUMP S5-1	ON	HEAT/COOL*	
	OFF	HEAT PUMP	
DE-HUMIDIFIER S5-2	ON	NOT INSTALLED*	
	OFF	INSTALLED	

* FACTORY SETTING

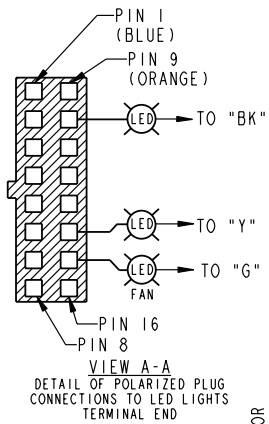

IMPORTANT: INTEGRATED CONTROL IS POLARITY SENSITIVE. HOT LEG OF 120V POWER SUPPLY MUST BE CONNECTED TO THE BLACK POWER LEAD AS INDICATED ON WIRING DIAGRAM.

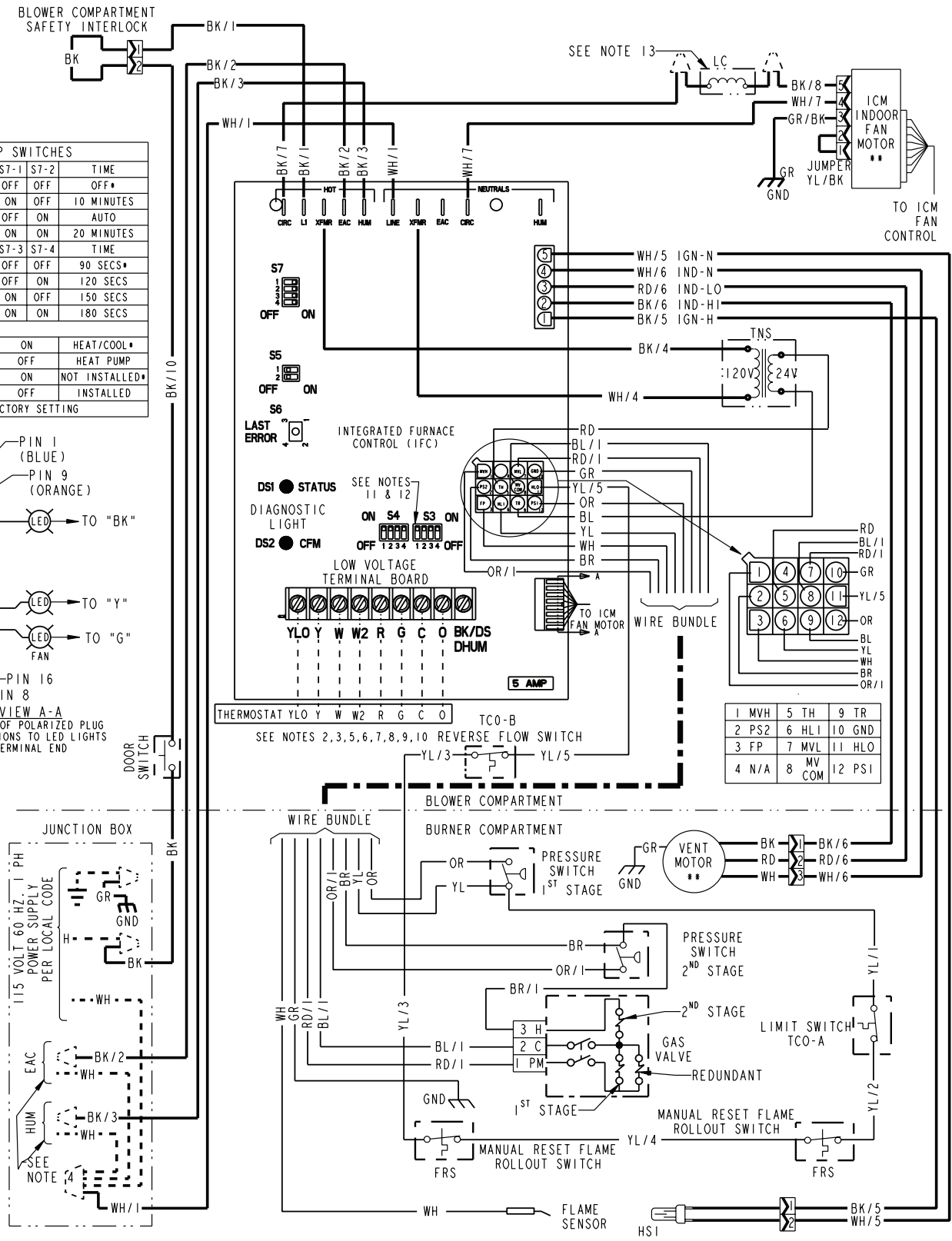

(continued on next page)

From Dwg. D344248P02

Schematic Diagram

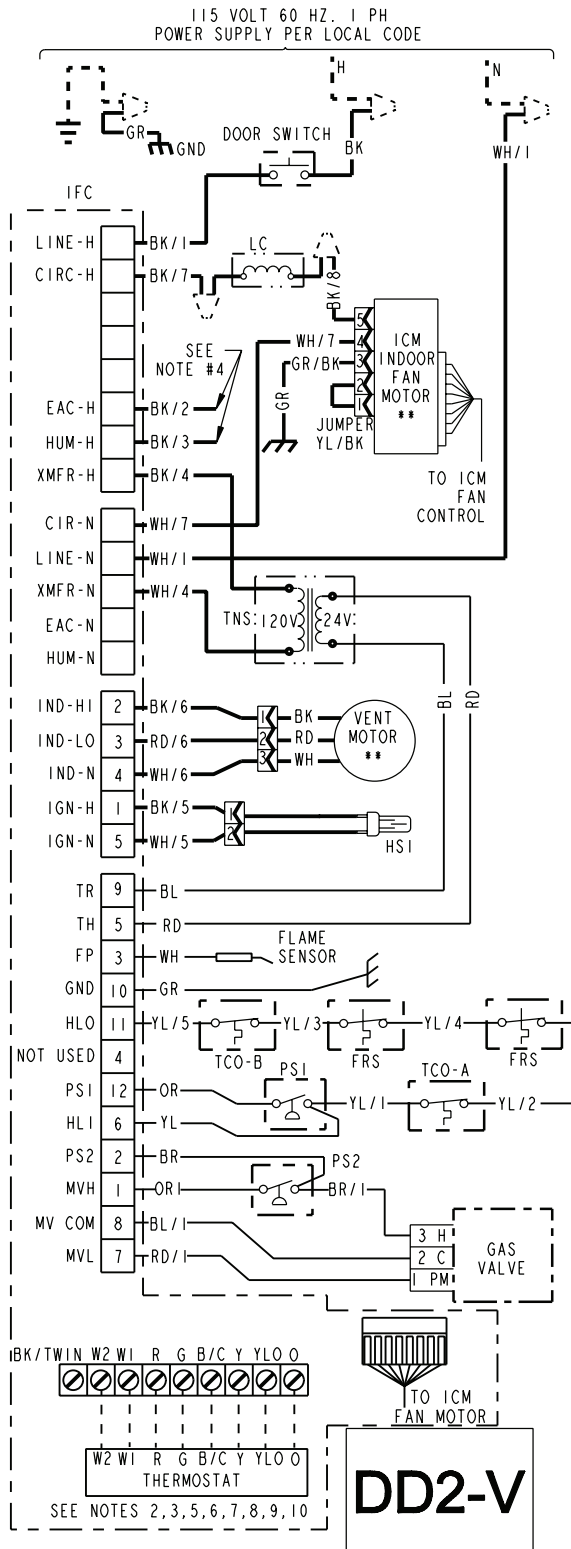
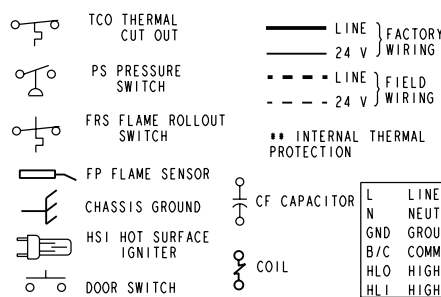

TABLE "A"	
MODELS	
*DD2B060A9V3V**	
*DD2B080A9V3V**	
*DD2C100A9V5V**	
*DD2D120A9V5V**	
* PREFIX MAY BE "A" OR "T"	
** SUFFIX MAY BE "A" THROUGH "Z"	

- DIAGNOSTIC CODES**
- RED LED FLASH:**
- 1 FLASH : FLAME SENSED WHEN NO FLAME SHOULD BE PRESENT
 - 2 FLASHES: PRESSURE SWITCH STUCK CLOSED
 - 3 FLASHES: 1ST-STAGE PRESSURE SWITCH STUCK OPEN/ NOT CLOSING
 - 4 FLASHES: OPEN THERMAL LIMIT OR OPEN ROLLOUT
 - 5 FLASHES: OPEN LOW VOLTAGE FUSE
 - 6 FLASHES: 1ST STAGE PRESSURE SWITCH OPENED 5 TIMES WITHIN ONE CYCLE --1 HOUR LOCKOUT
 - 7 FLASHES: SYSTEM LOCKOUT (RETRY)
 - 8 FLASHES: SYSTEM LOCKOUT (RECYCLE)
 - 9 FLASHES: REVERSE POLARITY OR POOR GROUNDING
 - 10 FLASHES: GAS VALVE ENERGIZED WITH NO CALL FOR HEAT
 - 12 FLASHES: IGNITOR RELAY FAILURE INTERNAL IN BOARD, REPLACE 'IFC'
- SOLID :** GAS VALVE RELAY FAILURE INTERNAL IN BOARD, REPLACE 'IFC'
- 3 DOUBLE :** 2ND STAGE PRESSURE SWITCH OPEN SYSTEM REVERTS TO 1ST STAGE HEAT
- AMBER LED FLASH:**
- 1 FLASH : 1ST STAGE CALL FOR HEAT
 - 2 FLASHES: 2ND STAGE CALL FOR HEAT
 - 3 FLASHES: W2 CALL PRESENT WITH NO W1
 - 4 FLASHES: Y PRESENT WITH NO G CALL
- RAPID :** LOW FLAME SENSE CURRENT
- GREEN LED FLASH:**
- 1 FLASH: STANDBY MODE OF CALL FOR COOLING



WARNING

HAZARDOUS VOLTAGE:
DISCONNECT ALL ELECTRICAL POWER INCLUDING REMOTE DISCONNECTS BEFORE SERVICING.
FAILURE TO DISCONNECT POWER BEFORE SERVICING CAN CAUSE SEVERE PERSONAL INJURY OR DEATH.

CAUTION

USE COPPER CONDUCTORS ONLY!
UNIT TERMINALS ARE NOT DESIGNED TO ACCEPT OTHER TYPES OF CONDUCTORS.
FAILURE TO DO SO MAY CAUSE DAMAGE TO THE EQUIPMENT.

INTEGRATED FURNACE CONTROL

REPLACE WITH PART CNT06015 OR EQUIVALENT

ELECTRICAL RATING

INPUT: 25 VAC, 60 HZ.
XFMR SEC. CURRENT: 450 MA.
MV 1ST STAGE OUTPUT: 1.5 A @ 24 VAC
MV 2ND STAGE OUTPUT: 0.5 A @ 24 VAC
IND OUTPUT: 2.2 FLA, 3.5 LRA @ 120 VAC
CIRC. BLOWER OUTPUT: 14.5 FLA, 25 LRA @ 120 VAC
HUMIDIFIER & AIR CLEANER
MAX. LOAD: 1.0 A @ 120 VAC
IGNITER OUTPUT: 2.0 A @ 120 VAC

TIMINGS

IGN WARMUP: 20 SEC.
RETRIES: 2 RECYCLES: 10
HEAT ON DELAY: 45 SEC.
COOL ON DELAY: 2 SEC.

BK	BLACK	GR	GREEN
WH	WHITE	BR	BROWN
YL	YELLOW	RD	RED
OR	ORANGE	BL	BLUE

WIRE COLOR

BK/1	NUMBER ID (IF ANY)
------	--------------------

L	LINE	TR	24 VAC (HOT)
N	NEUTRAL	TR	24 VAC (COMMON)
GND	GROUND	MV	MAIN GAS VALVE
B/C	COMMON	TNS	TRANSFORMER
HLO	HIGH LIMIT OUTPUT		
HLI	HIGH LIMIT INPUT		

- NOTES:**
- IF ANY OF THE ORIGINAL WIRING AS SUPPLIED WITH THIS FURNACE MUST BE REPLACED, IT MUST BE WITH WIRE HAVING A TEMPERATURE RATING OF AT LEAST 105 C.
 - THERMOSTAT HEAT ANTICIPATOR SETTING: FIRST STAGE 38 AMPS, SECOND STAGE .13 AMPS. IF SETTING IS NOT FIXED ON THERMOSTAT, FOR SINGLE STAGE HEATING THERMOSTAT SET AT .51 AMPS.
 - FOR PROPER OPERATION OF COOLING SPEED, "Y" TERMINAL MUST BE CONNECTED TO THE ROOM THERMOSTAT.
 - THESE LEADS PROVIDE 120V POWER CONNECTIONS FOR ELECTRONIC AIR CLEANER (EAC) AND HUMIDIFIER (HUM), MAX. LOAD: 1.0 AMPS EACH.
 - WHEN USING A SINGLE STAGE HEATING THERMOSTAT, THE 2ND STAGE HEAT DELAY IS CONTROLLED BY S7-1 & S7-2. REFERENCE THE SERVICE FACTS FOR DIP SWITCH CONFIGURATIONS.
 - GREEN LIGHT (CFM) FLASHES ONCE PER 100 CFM COMMAND.
 - FOR HEAT PUMP SYSTEMS Y AND O MUST BE CONNECTED TO THE LOW-VOLTAGE TERMINAL BOARD.
 - FOR TWO COMPRESSOR SYSTEMS, USE "YLO" FOR LOW SPEED AND "Y" FOR HIGH SPEED CONNECTION TO THE LOW-VOLTAGE TERMINAL BOARD. FOR TWO STEP SCROLL SYSTEM, USE "Y" FOR LOW SPEED AND "BK" FOR HIGH SPEED CONNECTIONS ON THE LOW VOLTAGE TERMINAL BOARD. PLACE A JUMPER BETWEEN "R" AND "O" AND MOVE 'S5-2' TO THE 'OFF' POSITION.
 - OPTIONAL HUMIDISTAT IS TO BE CONNECTED BETWEEN "R" & "BK". **DO NOT CUT ANY JUMPERS ON THIS BOARD.** SWITCH 'S5-2' MUST BE SET IN THE 'OFF' POSITION IF HUMIDISTAT IS USED. THE 'S5-2' SWITCH MUST ALSO BE TURNED TO 'OFF' WHEN APPLYING AN AIRFLOW COMMAND SIGNAL TO "BK". THE "BK" TERMINAL MUST BE USED WHEN APPLYING A HUMIDISTAT, A 402 THERMOSTAT (WITH "BK" ENABLED), A TWO STEP SCROLL COMPRESSOR OR RESIDENTIAL ZONING SYSTEM.
 - A JUMPER MUST BE PLACED BETWEEN "R" & "O" TO ENABLE THE "BK" CIRCUIT OR ENHANCED MODE (COMFORT R). THIS "R" TO "O" JUMPER MUST BE IN PLACE FOR HUMIDISTAT DEHUMIDIFICATION AND PROPER BLOWER OPERATION WITH A TWO STEP SCROLL COMPRESSOR.
 - SEE INDOOR MOTOR AIRFLOW SELECTION CHART, LOCATED IN THE FURNACE FOR DIP SWITCH SETTINGS TO SET AIRFLOW AND COOLING OFF DELAYS.
 - POWER MUST BE OFF WHEN DIP SWITCHES ARE SET.
 - USED ON ALL DOWNFLOW VARIABLE SPEED MODELS EXCEPT FOR *DD2B060A9V3V** AND *DD2B080A9V3V**.

Service Facts

*UD2B060A9V3VB FURNACE HEATING AIRFLOW (CFM) AND POWER (WATTS) VS. EXTERNAL STATIC PRESSURE WITH FILTER									
	AIRFLOW SETTING	DIP SWITCH SETTING			EXTERNAL STATIC PRESSURE				
		S4-3	S4-4		0.1	0.3	0.5	0.7	0.9
HEATING 1ST STAGE	LOW	ON	ON	CFM TEMP. RISE WATTS	589 49 65	604 48 95	619 47 125	604 48 160	607 48 200
	MEDIUM **	ON	OFF	CFM TEMP. RISE WATTS	663 44 75	694 42 120	684 42 145	681 42 185	686 42 220
	HIGH	OFF	OFF	CFM TEMP. RISE WATTS	775 37 105	781 37 145	776 37 180	805 36 230	811 36 270
HEATING 2ND STAGE	LOW	ON	ON	CFM TEMP. RISE WATTS	813 55 110	818 54 150	818 54 185	837 53 240	842 53 280
	MEDIUM **	ON	OFF	CFM TEMP. RISE WATTS	907 49 140	919 48 200	942 47 240	958 46 300	959 46 330
	HIGH	OFF	OFF	CFM TEMP. RISE WATTS	1038 43 190	1066 42 260	1086 41 325	1089 41 365	1079 41 415

*UD2B060A9V3VB FURNACE COOLING AIRFLOW (CFM) AND POWER (WATTS) VS. EXTERNAL STATIC PRESSURE WITH FILTER											
OUTDOOR UNIT SIZE (TONS)	AIRFLOW SETTING	DIP SWITCH SETTING					EXTERNAL STATIC PRESSURE				
		S3-1	S3-2	S3-3	S3-4		0.1	0.3	0.5	0.7	0.9
1.5	LOW (350 CFM/ TON)	ON	ON	OFF	ON	CFM WATTS	499 50	537 80	520 110	520 145	500 175
	NORMAL (400 CFM/ TON)	ON	ON	OFF	OFF	CFM WATTS	605 60	610 80	610 120	597 155	593 180
	HIGH (450 CFM/ TON)	ON	ON	ON	OFF	CFM WATTS	649 75	681 110	665 145	665 180	672 220
2.0	LOW (350 CFM/ TON)	OFF	ON	OFF	ON	CFM WATTS	680 80	722 125	680 150	696 190	696 225
	NORMAL (400 CFM/ TON)	OFF	ON	OFF	OFF	CFM WATTS	798 105	804 145	809 170	823 235	818 280
	HIGH (450 CFM/ TON)	OFF	ON	ON	OFF	CFM WATTS	884 145	896 180	924 240	931 280	931 330
2.5	LOW (350 CFM/ TON)	ON	OFF	OFF	ON	CFM WATTS	858 125	863 175	882 220	894 275	895 320
	NORMAL (400 CFM/ TON)	ON	OFF	OFF	OFF	CFM WATTS	984 170	1017 225	1038 295	1017 330	1017 375
	HIGH (450 CFM/ TON)	ON	OFF	ON	OFF	CFM WATTS	1125 245	1138 315	1150 370	1161 435	1161 475
3.0 **	LOW (350 CFM/ TON)	OFF	OFF	OFF	ON	CFM WATTS	1035 205	1056 265	1076 330	1076 370	1076 430
	NORMAL ** (400 CFM/ TON)	OFF	OFF	OFF	OFF	CFM WATTS	1208 300	1247 360	1268 440	1278 485	1200 490
	HIGH (450 CFM/ TON)	OFF	OFF	ON	OFF	CFM WATTS	1380 440	1410 500	1402 550	1350 550	1235 525

NOTES:

- *FIRST LETTER MAY BE "A" OR "T"
- **FACTORY SETTING.
- CONTINUOUS FAN SETTING: HEATING OR COOLING AIRFLOW IS APPROXIMATELY 50% OF SELECTED COOLING VALUE.
- LOW 350 CFM/TON IS RECOMMENDED FOR VARIABLE SPEED APPLICATION FOR COMFORT & HUMID CLIMATE SETTING:
NORMAL IS 400 CFM/TON: HIGH 450 CFM/TON IS FOR DRY CLIMATE SETTING.

Service Facts

*UD2B080A9V3VB FURNACE HEATING AIRFLOW (CFM) AND POWER (WATTS) VS. EXTERNAL STATIC PRESSURE WITH FILTER									
	AIRFLOW SETTING	DIP SWITCH SETTING			EXTERNAL STATIC PRESSURE				
		S4-3	S4-4		0.1	0.3	0.5	0.7	0.9
HEATING 1ST STAGE	LOW	ON	ON	CFM TEMP. RISE WATTS	800 48 100	790 49 135	765 50 155	750 52 200	730 53 230
	MEDIUM **	ON	OFF	CFM TEMP. RISE WATTS	910 43 130	890 44 170	875 44 210	860 45 240	820 47 280
	HIGH	OFF	OFF	CFM TEMP. RISE WATTS	1060 37 188	1020 38 220	1010 39 265	1010 39 310	1000 39 350
HEATING 2ND STAGE	LOW	ON	ON	CFM TEMP. RISE WATTS	1110 54 210	1090 55 260	1090 55 310	1080 55 350	1065 56 400
	MEDIUM **	ON	OFF	CFM TEMP. RISE WATTS	1245 48 300	1240 48 355	1240 48 410	1230 48 460	1215 49 500
	HIGH	OFF	OFF	CFM TEMP. RISE WATTS	1415 42 410	1400 42 470	1400 42 530	1375 43 580	1320 45 590

*UD2B080A9V3VB FURNACE COOLING AIRFLOW (CFM) AND POWER (WATTS) VS. EXTERNAL STATIC PRESSURE WITH FILTER											
OUTDOOR UNIT SIZE (TONS)	AIRFLOW SETTING	DIP SWITCH SETTING					EXTERNAL STATIC PRESSURE				
		S3-1	S3-2	S3-3	S3-4		0.1	0.3	0.5	0.7	0.9
2.5	LOW (350 CFM/TON)	OFF	ON	OFF	ON	CFM WATTS	880 120	875 155	860 190	845 225	840 245
	NORMAL (400 CFM/TON)	OFF	ON	OFF	OFF	CFM WATTS	1020 170	1000 205	990 240	980 280	960 320
	HIGH (450 CFM/TON)	OFF	ON	ON	OFF	CFM WATTS	1110 210	110 260	1110 320	1100 350	1100 385
3.0	LOW (350 CFM/TON)	ON	OFF	OFF	ON	CFM WATTS	1040 190	1010 220	1000 260	1000 310	990 340
	NORMAL (400 CFM/TON)	ON	OFF	OFF	OFF	CFM WATTS	1200 250	1200 320	1190 370	1190 415	1175 450
	HIGH (450 CFM/TON)	ON	OFF	ON	OFF	CFM WATTS	1340 355	1340 425	1330 475	1320 530	1300 570
3.5 **	LOW (350 CFM/TON)	OFF	OFF	OFF	ON	CFM WATTS	1215 265	1210 330	1210 375	1200 430	1185 465
	NORMAL ** (400 CFM/TON)	OFF	OFF	OFF	OFF	CFM WATTS	1430 415	1415 457	1410 520	1385 575	1330 580
	HIGH (450 CFM/TON)	OFF	OFF	ON	OFF	CFM WATTS	1430 415	1415 475	1410 520	1385 575	1330 580

NOTES:

- * First Letter may be "A" or "T"
- ** Factory setting
- Continuous Fan Setting: Heating or Cooling airflow is approximately 50% of selected Cooling value.
- LOW 350 cfm/ton is recommended for Variable Speed application for COMFORT & HUMID CLIMATE setting; NORMAL is 400 cfm/ton; HIGH 450 cfm/ton is for DRY CLIMATE setting

Service Facts

*UD2C080A9V4VB FURNACE HEATING AIRFLOW (CFM) AND POWER (WATTS) VS. EXTERNAL STATIC PRESSURE WITH FILTER									
	AIRFLOW SETTING	DIP SWITCH SETTING			EXTERNAL STATIC PRESSURE				
		S4-3	S4-4		0.1	0.3	0.5	0.7	0.9
HEATING 1ST STAGE	LOW	ON	ON	CFM TEMP. RISE WATTS	782 49 75	762 51 110	751 51 145	748 51 185	737 52 225
	MEDIUM **	ON	OFF	CFM TEMP. RISE WATTS	870 44 90	865 45 125	861 45 175	848 45 215	831 46 255
	HIGH	OFF	OFF	CFM TEMP. RISE WATTS	962 40 110	974 40 155	963 40 200	938 41 245	914 42 290
HEATING 2ND STAGE	LOW	ON	ON	CFM TEMP. RISE WATTS	1091 54 145	1092 54 190	1087 55 245	1092 54 305	1077 55 355
	MEDIUM **	ON	OFF	CFM TEMP. RISE WATTS	1211 49 190	1243 48 255	1243 48 310	1244 48 370	1235 48 430
	HIGH	OFF	OFF	CFM TEMP. RISE WATTS	1371 43 255	1388 43 325	1392 43 395	1385 43 455	1377 43 515

*UD2C080A9V4VB FURNACE COOLING AIRFLOW (CFM) AND POWER (WATTS) VS. EXTERNAL STATIC PRESSURE WITH FILTER											
OUTDOOR UNIT SIZE (TONS)	AIRFLOW SETTING	DIP SWITCH SETTING					EXTERNAL STATIC PRESSURE				
		S3-1	S3-2	S3-3	S3-4		0.1	0.3	0.5	0.7	0.9
2.5	LOW (350 CFM/TON)	ON	ON	OFF	ON	CFM WATTS	863 90	865 130	858 175	843 220	831 255
	NORMAL (400 CFM/TON)	ON	ON	OFF	OFF	CFM WATTS	995 115	1005 170	989 210	973 260	956 305
	HIGH (450 CFM/TON)	ON	ON	ON	OFF	CFM WATTS	1101 150	1112 200	1111 255	1107 305	1101 360
3.0	LOW (350 CFM/TON)	OFF	ON	OFF	ON	CFM WATTS	1031 125	1031 175	1026 215	1013 270	1003 320
	NORMAL (400 CFM/TON)	OFF	ON	OFF	OFF	CFM WATTS	1163 170	1178 230	1188 285	1183 345	1178 405
	HIGH (450 CFM/TON)	OFF	ON	ON	OFF	CFM WATTS	1319 240	1337 305	1344 365	1340 420	1336 485
3.5	LOW (350 CFM/TON)	ON	OFF	OFF	ON	CFM WATTS	1182 200	1206 240	1211 295	1211 350	1211 420
	NORMAL (400 CFM/TON)	ON	OFF	OFF	OFF	CFM WATTS	1380 255	1401 325	1402 390	1402 460	1399 515
	HIGH (450 CFM/TON)	ON	OFF	ON	OFF	CFM WATTS	1553 350	1566 425	1557 500	1558 560	1559 645
4.0 **	LOW (350 CFM/TON)	OFF	OFF	OFF	ON	CFM WATTS	1386 255	1401 330	1408 395	1402 460	1390 520
	NORMAL ** (400 CFM/TON)	OFF	OFF	OFF	OFF	CFM WATTS	1590 360	1593 440	1591 515	1588 575	1576 650
	HIGH (450 CFM/TON)	OFF	OFF	ON	OFF	CFM WATTS	1791 360	1808 615	1810 615	1808 775	1726 800

NOTES:

- * First Letter may be "A" or "T"
- ** Factory setting
- Continuous Fan Setting: Heating or Cooling airflow is approximately 50% of selected Cooling value.
- LOW 350 cfm/ton is recommended for Variable Speed application for COMFORT & HUMID CLIMATE setting; NORMAL is 400 cfm/ton; HIGH 450 cfm/ton is for DRY CLIMATE setting

Service Facts

*UD2C080B9V4VB FURNACE HEATING AIRFLOW (CFM) AND POWER (WATTS) VS. EXTERNAL STATIC PRESSURE WITH FILTER									
	AIRFLOW SETTING	DIP SWITCH SETTING			EXTERNAL STATIC PRESSURE				
		S4-3	S4-4		0.1	0.3	0.5	0.7	0.9
HEATING 1ST STAGE	LOW	ON	ON	CFM TEMP. RISE WATTS	974 49 133	968 49 285	949 50 202	925 51 254	906 52 304
	MEDIUM **	ON	OFF	CFM TEMP. RISE WATTS	1102 43 93	1112 43 144	1103 43 201	1083 44 255	1066 45 305
	HIGH	OFF	OFF	CFM TEMP. RISE WATTS	1194 40 119	1217 39 180	1215 39 243	1200 40 304	1182 40 362
HEATING 2ND STAGE	LOW	ON	ON	CFM TEMP. RISE WATTS	1189 58 142	1210 57 209	1209 57 276	1193 58 341	1175 58 404
	MEDIUM **	ON	OFF	CFM TEMP. RISE WATTS	1346 51 141	1388 49 207	1398 49 274	1390 49 339	1372 50 401
	HIGH	OFF	OFF	CFM TEMP. RISE WATTS	1460 47 186	1516 45 263	1536 45 335	1533 45 407	1515 45 477

*UD2C080B9V4VB FURNACE COOLING AIRFLOW (CFM) AND POWER (WATTS) VS. EXTERNAL STATIC PRESSURE WITH FILTER											
OUTDOOR UNIT SIZE (TONS)	AIRFLOW SETTING	DIP SWITCH SETTING					EXTERNAL STATIC PRESSURE				
		S3-1	S3-2	S3-3	S3-4		0.1	0.3	0.5	0.7	0.9
2.5	LOW (350 CFM/TON)	ON	ON	OFF	ON	CFM WATTS	842 71	819 114	789 163	756 207	740 249
	NORMAL (400 CFM/TON)	ON	ON	OFF	OFF	CFM WATTS	956 90	948 140	928 196	901 248	884 298
	HIGH (450 CFM/TON)	ON	ON	ON	OFF	CFM WATTS	1071 113	1078 171	1067 233	1045 292	1028 348
3.0	LOW (350 CFM/TON)	OFF	ON	OFF	ON	CFM WATTS	1002 99	1000 152	983 210	958 265	942 318
	NORMAL (400 CFM/TON)	OFF	ON	OFF	OFF	CFM WATTS	1140 128	1155 191	1150 256	1132 319	1114 379
	HIGH (450 CFM/TON)	OFF	ON	ON	OFF	CFM WATTS	1278 165	1311 238	1316 308	1305 377	1287 444
3.5	LOW (350 CFM/TON)	ON	OFF	OFF	ON	CFM WATTS	1163 134	1181 199	1177 265	1161 328	1143 389
	NORMAL (400 CFM/TON)	ON	OFF	OFF	OFF	CFM WATTS	1324 179	1363 255	1372 326	1363 397	1345 466
	HIGH (450 CFM/TON)	ON	OFF	ON	OFF	CFM WATTS	1485 234	1544 319	1566 396	1565 472	1546 550
4.0 **	LOW (350 CFM/TON)	OFF	OFF	OFF	ON	CFM WATTS	1324 179	1363 255	1372 326	1363 397	1345 466
	NORMAL ** (400 CFM/TON)	OFF	OFF	OFF	OFF	CFM WATTS	1508 243	1570 329	1594 407	1593 483	1575 562
	HIGH (450 CFM/TON)	OFF	OFF	ON	OFF	CFM WATTS	1691 322	1777 416	1816 499	1824 579	1805 669

NOTES:

- * First Letter may be "A" or "T"
- ** Factory setting
- Continuous Fan Setting: Heating or Cooling airflow is approximately 50% of selected Cooling value.
- LOW 350 cfm/ton is recommended for Variable Speed application for COMFORT & HUMID CLIMATE setting; NORMAL is 400 cfm/ton; HIGH 450 cfm/ton is for DRY CLIMATE setting

Service Facts

*UD2B100A9V3VB FURNACE HEATING AIRFLOW (CFM) AND POWER (WATTS) VS. EXTERNAL STATIC PRESSURE WITH FILTER									
	AIRFLOW SETTING	DIP SWITCH SETTING			EXTERNAL STATIC PRESSURE				
		S4-3	S4-4		0.1	0.3	0.5	0.7	0.9
HEATING 1ST STAGE	LOW	ON	ON	CFM TEMP. RISE WATTS	751 64 86	796 61 132	817 59 175	832 58 218	838 57 263
	MEDIUM **	ON	OFF	CFM TEMP. RISE WATTS	862 56 121	921 52 185	953 51 233	967 50 285	954 50 322
	HIGH	OFF	OFF	CFM TEMP. RISE WATTS	959 50 148	1002 48 210	1036 46 280	1036 46 325	1003 48 355
HEATING 2ND STAGE	LOW	ON	ON	CFM TEMP. RISE WATTS	1099 67 227	1124 66 287	1149 64 355	1157 64 415	1055 70 395
	MEDIUM **	ON	OFF	CFM TEMP. RISE WATTS	1286 58 365	1321 56 450	1313 56 455	1215 61 475	1119 66 450
	HIGH	OFF	OFF	CFM TEMP. RISE WATTS	1399 53 465	1419 52 570	1347 55 545	1265 59 520	1163 64 485

*UD2B100A9V3VB FURNACE COOLING AIRFLOW (CFM) AND POWER (WATTS) VS. EXTERNAL STATIC PRESSURE WITH FILTER											
OUTDOOR UNIT SIZE (TONS)	AIRFLOW SETTING	DIP SWITCH SETTING					EXTERNAL STATIC PRESSURE				
		S3-1	S3-2	S3-3	S3-4		0.1	0.3	0.5	0.7	0.9
1.5	LOW (350 CFM/TON)	ON	ON	OFF	ON	CFM WATTS	516 50	536 75	551 105	547 135	530 165
	NORMAL (400 CFM/TON)	ON	ON	OFF	OFF	CFM WATTS	583 59	615 92	633 127	621 157	618 18
	HIGH (450 CFM/TON)	ON	ON	ON	OFF	CFM WATTS	681 70	697 110	701 140	709 180	712 215
2.0	LOW (350 CFM/TON)	OFF	ON	OFF	ON	CFM WATTS	680 75	726 120	735 150	741 190	745 230
	NORMAL (400 CFM/TON)	OFF	ON	OFF	OFF	CFM WATTS	769 103	819 145	843 190	858 235	865 286
	HIGH (450 CFM/TON)	OFF	ON	ON	OFF	CFM WATTS	882 130	938 190	961 245	975 300	970 345
2.5	LOW (350 CFM/TON)	ON	OFF	OFF	ON	CFM WATTS	831 180	903 180	928 230	935 275	935 320
	NORMAL (400 CFM/TON)	ON	OFF	OFF	OFF	CFM WATTS	979 167	1036 240	1053 295	1053 345	1015 368
	HIGH (450 CFM/TON)	ON	OFF	ON	OFF	CFM WATTS	1121 245	1147 310	1176 383	1167 442	1055 396
3.0**	LOW (350 CFM/TON)	OFF	OFF	OFF	ON	CFM WATTS	1061 210	1081 265	1095 320	1101 382	1032 380
	NORMAL ** (400 CFM/TON)	OFF	OFF	OFF	OFF	CFM WATTS	1185 278	1223 364	1251 435	1205 455	1101 426
	HIGH (450 CFM/TON)	OFF	OFF	ON	OFF	CFM WATTS	1351 425	1372 503	1343 535	1248 505	1168 480

NOTES:

- * First Letter may be "A" or "T"
- ** Factory setting
- Continuous Fan Setting: Heating or Cooling airflow is approximately 50% of selected Cooling value.
- LOW 350 cfm/ton is recommended for Variable Speed application for COMFORT & HUMID CLIMATE setting; NORMAL is 400 cfm/ton; HIGH 450 cfm/ton is for DRY CLIMATE setting

Service Facts

*UD2C100A9V5VB FURNACE HEATING AIRFLOW (CFM) AND POWER (WATTS) VS. EXTERNAL STATIC PRESSURE WITH FILTER									
	AIRFLOW SETTING	DIP SWITCH SETTING			EXTERNAL STATIC PRESSURE				
		S4-3	S4-4		0.1	0.3	0.5	0.7	0.9
HEATING 1ST STAGE	LOW	ON	ON	CFM TEMP. RISE WATTS	900 53 100	890 54 130	870 55 175	850 57 220	835 58 270
	MEDIUM **	ON	OFF	CFM TEMP. RISE WATTS	1125 43 150	1090 44 200	1060 46 235	1070 45 300	1070 45 340
	HIGH	OFF	OFF	CFM TEMP. RISE WATTS	1300 37 220	1300 37 290	1320 36 365	1350 36 430	1340 36 490
HEATING 2ND STAGE	LOW	ON	ON	CFM TEMP. RISE WATTS	1270 59 200	1290 58 260	1290 58 335	1290 58 400	1280 58 460
	MEDIUM **	ON	OFF	CFM TEMP. RISE WATTS	1575 47 355	1600 46 445	1610 46 520	1600 46 575	1580 47 650
	HIGH	OFF	OFF	CFM TEMP. RISE WATTS	1870 40 560	1890 39 665	1860 40 710	1870 40 830	1730 43 760

*UD2C100A9V5VB FURNACE COOLING AIRFLOW (CFM) AND POWER (WATTS) VS. EXTERNAL STATIC PRESSURE WITH FILTER											
OUTDOOR UNIT SIZE (TONS)	AIRFLOW SETTING	DIP SWITCH SETTING					EXTERNAL STATIC PRESSURE				
		S3-1	S3-2	S3-3	S3-4		0.1	0.3	0.5	0.7	0.9
3.0	LOW (350 CFM/TON)	ON	ON	OFF	ON	CFM WATTS	1075 135	1055 185	1015 220	1000 265	990 325
	NORMAL (400 CFM/TON)	ON	ON	OFF	OFF	CFM WATTS	1220 185	1200 240	1210 295	1210 350	1210 410
	HIGH (450 CFM/TON)	ON	ON	ON	OFF	CFM WATTS	1390 245	1390 320	1410 391	1410 470	1400 510
3.5	LOW (350 CFM/TON)	OFF	ON	OFF	ON	CFM WATTS	1214 185	1210 240	1215 295	1210 350	1210 415
	NORMAL (400 CFM/TON)	OFF	ON	OFF	OFF	CFM WATTS	1430 310	1460 355	1470 430	1460 500	1440 555
	HIGH (450 CFM/TON)	OFF	ON	ON	OFF	CFM WATTS	1640 370	1665 460	1650 540	1640 615	1610 660
4.0	LOW (350 CFM/TON)	ON	OFF	OFF	ON	CFM WATTS	1405 270	1430 310	1440 375	1440 480	1420 550
	NORMAL (400 CFM/TON)	ON	OFF	OFF	OFF	CFM WATTS	1670 395	1675 490	1670 550	1655 630	1630 700
	HIGH (450 CFM/TON)	ON	OFF	ON	OFF	CFM WATTS	1870 540	1880 635	1880 730	1845 800	1670 640
5.0 **	LOW (350 CFM/TON)	OFF	OFF	OFF	ON	CFM WATTS	1775 480	1800 580	1820 680	1800 750	1680 740
	NORMAL ** (400 CFM/TON)	OFF	OFF	OFF	OFF	CFM WATTS	2065 755	2020 840	1945 900	1805 880	1623 800
	HIGH (450 CFM/TON)	OFF	OFF	ON	OFF	CFM WATTS	2310 1000	2100 1000	2100 950	1965 890	1800 825

NOTES:

- * First letter may be "A" or "T"
- ** Factory setting
- Continuous Fan Setting: Heating or Cooling airflow is approximately 50% of selected Cooling value.
- LOW 350 cfm/ton is recommended for Variable Speed application for COMFORT & HUMID CLIMATE setting; NORMAL is 400 cfm/ton; HIGH 450 cfm/ton is for DRY CLIMATE setting

Service Facts

*UD2C100B9V5VB FURNACE HEATING AIRFLOW (CFM) AND POWER (WATTS) VS. EXTERNAL STATIC PRESSURE WITH FILTER									
	AIRFLOW SETTING	DIP SWITCH SETTING			EXTERNAL STATIC PRESSURE				
		S4-3	S4-4		0.1	0.3	0.5	0.7	0.9
HEATING 1ST STAGE	LOW	ON	ON	CFM TEMP. RISE WATTS	953 50 93	944 50 146	936 51 193	908 52 243	887 54 292
	MEDIUM **	ON	OFF	CFM TEMP. RISE WATTS	1142 42 135	1141 42 200	1135 42 255	1112 43 322	1098 43 377
	HIGH	OFF	OFF	CFM TEMP. RISE WATTS	1258 38 169	1260 38 240	1256 38 302	1236 38 378	1227 39 437
HEATING 2ND STAGE	LOW	ON	ON	CFM TEMP. RISE WATTS	1312 52 188	1317 52 261	1314 52 326	1294 53 406	1287 53 468
	MEDIUM **	ON	OFF	CFM TEMP. RISE WATTS	1577 44 301	1592 43 387	1592 43 468	1597 43 563	1582 43 644
	HIGH	OFF	OFF	CFM TEMP. RISE WATTS	1739 39 392	1761 39 486	1762 39 575	1753 39 675	1762 39 774

*UD2C100B9V5VB FURNACE COOLING AIRFLOW (CFM) AND POWER (WATTS) VS. EXTERNAL STATIC PRESSURE WITH FILTER											
OUTDOOR UNIT SIZE (TONS)	AIRFLOW SETTING	DIP SWITCH SETTING					EXTERNAL STATIC PRESSURE				
		S3-1	S3-2	S3-3	S3-4		0.1	0.3	0.5	0.7	0.9
3.0	LOW (350 CFM/TON)	ON	ON	OFF	ON	CFM WATTS	1056 114	1050 173	1044 225	1019 284	1002 336
	NORMAL (400 CFM/TON)	ON	ON	OFF	OFF	CFM WATTS	1199 151	1199 219	1194 277	1172 349	1161 405
	HIGH (450 CFM/TON)	ON	ON	ON	OFF	CFM WATTS	1342 198	1348 273	1345 340	1326 422	1320 486
3.5	LOW (350 CFM/TON)	OFF	ON	OFF	ON	CFM WATTS	1223 158	1224 227	1219 287	1198 361	1187 418
	NORMAL (400 CFM/TON)	OFF	ON	OFF	OFF	CFM WATTS	1389 217	1397 294	1395 363	1377 449	1373 515
	HIGH (450 CFM/TON)	OFF	ON	ON	OFF	CFM WATTS	1556 291	1570 376	1570 455	1556 549	1559 629
4.0	LOW (350 CFM/TON)	ON	OFF	OFF	ON	CFM WATTS	1389 217	1397 294	1395 363	1377 449	1373 515
	NORMAL (400 CFM/TON)	ON	OFF	OFF	OFF	CFM WATTS	1580 303	1595 389	1595 469	1582 565	1585 647
	HIGH (450 CFM/TON)	ON	OFF	ON	OFF	CFM WATTS	1770 411	1793 507	1795 598	1787 698	1797 801
5.0 **	LOW (350 CFM/TON)	OFF	OFF	OFF	ON	CFM WATTS	1723 382	1744 475	1754 564	1735 663	1744 760
	NORMAL ** (400 CFM/TON)	OFF	OFF	OFF	OFF	CFM WATTS	1961 546	1991 652	1996 751	1991 850	2010 981
	HIGH (450 CFM/TON)	OFF	OFF	ON	OFF	CFM WATTS	2199 754	2217 875	2217 983	2197 1067	1987 943

NOTES:

- * First letter may be "A" or "T"
- ** Factory setting
- Continuous Fan Setting: Heating or Cooling airflow is approximately 50% of selected Cooling value.
- LOW 350 cfm/ton is recommended for Variable Speed application for COMFORT & HUMID CLIMATE setting; NORMAL is 400 cfm/ton; HIGH 450 cfm/ton is for DRY CLIMATE setting

Service Facts

*UD2D120A9V5VB FURNACE HEATING AIRFLOW (CFM) AND POWER (WATTS) VS. EXTERNAL STATIC PRESSURE WITH FILTER									
	AIRFLOW SETTING	DIP SWITCH SETTING			EXTERNAL STATIC PRESSURE				
		S4-3	S4-4		0.1	0.3	0.5	0.7	0.9
HEATING 1ST STAGE	LOW	ON	ON	CFM TEMP. RISE WATTS	1007 57 114	1062 54 177	1084 53 285	1063 54 303	1063 54 350
	MEDIUM **	ON	OFF	CFM TEMP. RISE WATTS	1154 50 167	1211 48 230	1211 48 277	1221 47 344	1212 48 417
	HIGH	OFF	OFF	CFM TEMP. RISE WATTS	1288 45 208	1319 44 273	1310 44 330	1349 43 410	1358 43 460
HEATING 2ND STAGE	LOW	ON	ON	CFM TEMP. RISE WATTS	1387 64 250	1421 63 320	1455 61 400	1488 60 460	1495 59 540
	MEDIUM **	ON	OFF	CFM TEMP. RISE WATTS	1589 56 350	1637 54 440	1666 53 535	1678 53 600	1541 58 575
	HIGH	OFF	OFF	CFM TEMP. RISE WATTS	1771 50 475	1788 50 560	1804 49 650	1751 51 675	1554 57 590

*UD2D120A9V5VB FURNACE COOLING AIRFLOW (CFM) AND POWER (WATTS) VS. EXTERNAL STATIC PRESSURE WITH FILTER											
OUTDOOR UNIT SIZE (TONS)	AIRFLOW SETTING (See Notes)	DIP SWITCH SETTING					EXTERNAL STATIC PRESSURE				
		S3-1	S3-2	S3-3	S3-4		0.1	0.3	0.5	0.7	0.9
3.5	LOW (350 CFM/ TON)	OFF	ON	OFF	ON	CFM WATTS	1195 150	1243 225	1235 275	1251 325	1251 410
	NORMAL (400 CFM/ TON)	OFF	ON	OFF	OFF	CFM WATTS	1353 210	1403 290	1417 370	1437 425	1458 485
	HIGH (450 CFM/ TON)	OFF	ON	ON	OFF	CFM WATTS	1554 315	1572 410	1615 480	1634 570	1567 575
4.0	LOW (350 CFM/ TON)	ON	OFF	OFF	ON	CFM WATTS	1356 200	1391 280	1399 370	1433 420	1454 510
	NORMAL (400 CFM/ TON)	ON	OFF	OFF	OFF	CFM WATTS	1565 320	1584 410	1633 475	1639 560	1554 575
	HIGH (450 CFM/ TON)	ON	OFF	ON	OFF	CFM WATTS	1766 450	1799 550	1810 650	1784 685	1590 600
5.0 **	LOW (350 CFM/ TON)	OFF	OFF	OFF	ON	CFM WATTS	1708 420	1758 530	1759 585	1775 675	1575 585
	NORMAL ** (400 CFM/ TON)	OFF	OFF	OFF	OFF	CFM WATTS	1994 665	2018 775	1971 785	1814 725	1618 625
	HIGH (450 CFM/ TON)	OFF	OFF	ON	OFF	CFM WATTS	2247 975	2152 925	2019 860	1861 765	1693 680

NOTES: "CONTINUOUS FAN SETTING" IS THERMOSTAT FAN SWITCH "ON" AND DIP SWITCHES 5 AND 6 "ON".

1. *FIRST LETTER MAY BE "A" OR "T"

2. **FACTORY SETTING.

3. CONTINUOUS FAN SETTING: HEATING OR COOLING AIRFLOW IS APPROXIMATELY 50% OF SELECTED COOLING VALUE.

4. LOW 350 CFM/TON IS RECOMMENDED FOR VARIABLE SPEED APPLICATION FOR COMFORT & HUMID CLIMATE SETTING:
NORMAL IS 400 CFM/TON: HIGH 450 CFM/TON IS FOR DRY CLIMATE SETTING.

Service Facts

*UD2D120B9V5VB FURNACE HEATING AIRFLOW (CFM) AND POWER (WATTS) VS. EXTERNAL STATIC PRESSURE WITH FILTER									
	AIRFLOW SETTING	DIP SWITCH SETTING			EXTERNAL STATIC PRESSURE				
		S4-3	S4-4		0.1	0.3	0.5	0.7	0.9
HEATING 1ST STAGE	LOW	ON	ON	CFM TEMP. RISE WATTS	1050 45 99	1044 46 146	1035 46 208	1005 47 252	980 48 310
	MEDIUM **	ON	OFF	CFM TEMP. RISE WATTS	1214 39 129	1216 39 188	1217 39 262	1192 40 252	1169 41 310
	HIGH	OFF	OFF	CFM TEMP. RISE WATTS	1288 37 147	1293 37 212	1298 37 293	1275 37 309	1254 38 373
HEATING 2ND STAGE	LOW	ON	ON	CFM TEMP. RISE WATTS	1429 48 191	1440 48 267	1453 47 363	1435 48 340	1416 48 406
	MEDIUM **	ON	OFF	CFM TEMP. RISE WATTS	1672 41 310	1695 40 402	1722 40 528	1711 40 409	1697 40 480
	HIGH	OFF	OFF	CFM TEMP. RISE WATTS	1782 39 385	1809 38 480	1890 36 623	1835 37 565	1871 37 644

*UD2D120B9V5VB FURNACE COOLING AIRFLOW (CFM) AND POWER (WATTS) VS. EXTERNAL STATIC PRESSURE WITH FILTER											
OUTDOOR UNIT SIZE (TONS)	AIRFLOW SETTING (See Notes)	DIP SWITCH SETTING					EXTERNAL STATIC PRESSURE				
		S3-1	S3-2	S3-3	S3-4		0.1	0.3	0.5	0.7	0.9
3.5	LOW (350 CFM/ TON)	OFF	ON	OFF	ON	CFM WATTS	1208 128	1209 186	1210 260	1185 306	1162 370
	NORMAL (400 CFM/ TON)	OFF	ON	OFF	OFF	CFM WATTS	1343 162	1350 232	1358 318	1337 365	1317 433
	HIGH (450 CFM/ TON)	OFF	ON	ON	OFF	CFM WATTS	1477 210	1491 290	1507 391	1490 436	1472 508
4.0	LOW (350 CFM/ TON)	ON	OFF	OFF	ON	CFM WATTS	1343 162	1350 232	1358 318	1337 365	1317 433
	NORMAL (400 CFM/ TON)	ON	OFF	OFF	OFF	CFM WATTS	1496 218	1511 300	1528 403	1511 447	1494 520
	HIGH (450 CFM/ TON)	ON	OFF	ON	OFF	CFM WATTS	1650 296	1671 387	1698 511	1686 548	1671 626
5.0 **	LOW (350 CFM/ TON)	OFF	OFF	OFF	ON	CFM WATTS	1612 274	1631 363	1655 482	1642 521	1627 598
	NORMAL ** (400 CFM/ TON)	OFF	OFF	OFF	OFF	CFM WATTS	1858 403	1902 533	1907 624	1906 714	1871 755
	HIGH (450 CFM/ TON)	OFF	OFF	ON	OFF	CFM WATTS	1871 585	2126 711	2110 797	2098 888	2001 953

NOTES: "CONTINUOUS FAN SETTING" IS THERMOSTAT FAN SWITCH "ON" AND DIP SWITCHES 5 AND 6 "ON".

1. *FIRST LETTER MAY BE "A" OR "T"

2. **FACTORY SETTING.

3. CONTINUOUS FAN SETTING: HEATING OR COOLING AIRFLOW IS APPROXIMATELY 50% OF SELECTED COOLING VALUE.

4. LOW 350 CFM/TON IS RECOMMENDED FOR VARIABLE SPEED APPLICATION FOR COMFORT & HUMID CLIMATE SETTING; NORMAL IS 400 CFM/TON; HIGH 450 CFM/TON IS FOR DRY CLIMATE SETTING.

Service Facts

*UD2D140A9V5VB FURNACE HEATING AIRFLOW (CFM) AND POWER (WATTS) VS. EXTERNAL STATIC PRESSURE WITH FILTER									
	AIRFLOW SETTING	DIP SWITCH SETTING			EXTERNAL STATIC PRESSURE				
		S4-3	S4-4		0.1	0.3	0.5	0.7	0.9
HEATING 1ST STAGE	LOW	ON	ON	CFM TEMP. RISE WATTS	1090 62 130	1100 61 175	1070 63 215	1080 62 255	1060 63 290
	MEDIUM **	ON	OFF	CFM TEMP. RISE WATTS	1230 55 180	1265 53 235	1280 53 315	1300 52 380	1300 52 455
	HIGH	OFF	OFF	CFM TEMP. RISE WATTS	1380 49 235	1405 48 290	1425 47 375	1430 47 415	1450 47 520
HEATING 2ND STAGE	LOW	ON	ON	CFM TEMP. RISE WATTS	1545 67 320	1550 67 385	1560 67 475	1560 67 540	1575 66 605
	MEDIUM **	ON	OFF	CFM TEMP. RISE WATTS	1760 59 435	1790 58 545	1810 58 620	1800 58 695	1725 60 725
	HIGH	OFF	OFF	CFM TEMP. RISE WATTS	2000 52 615	2010 52 715	2000 52 790	1950 54 820	1800 58 775

*UD2D140A9V5VB FURNACE COOLING AIRFLOW (CFM) AND POWER (WATTS) VS. EXTERNAL STATIC PRESSURE WITH FILTER											
OUTDOOR UNIT SIZE (TONS)	AIRFLOW SETTING	DIP SWITCH SETTING					EXTERNAL STATIC PRESSURE				
		S3-1	S3-2	S3-3	S3-4		0.1	0.3	0.5	0.7	0.9
3.5	LOW (350 CFM/TON)	OFF	ON	OFF	ON	CFM WATTS	1175 165	1165 200	1180 265	1170 320	1150 400
	NORMAL (400 CFM/TON)	OFF	ON	OFF	OFF	CFM WATTS	1345 225	1370 285	1400 360	1405 440	1380 490
	HIGH (450 CFM/TON)	OFF	ON	ON	OFF	CFM WATTS	1525 295	1565 390	1585 470	1575 515	1530 585
4.0	LOW (350 CFM/TON)	ON	OFF	OFF	ON	CFM WATTS	1320 220	1330 275	1335 355	1300 435	1240 490
	NORMAL (400 CFM/TON)	ON	OFF	OFF	OFF	CFM WATTS	1550 310	1580 400	1590 475	1555 540	1460 610
	HIGH (450 CFM/TON)	ON	OFF	ON	OFF	CFM WATTS	1735 430	1735 510	1710 600	1670 675	1590 710
5.0 **	LOW (350 CFM/TON)	OFF	OFF	OFF	ON	CFM WATTS	1700 415	1725 470	1730 560	1725 640	1690 700
	NORMAL ** (400 CFM/TON)	OFF	OFF	OFF	OFF	CFM WATTS	1980 616	1980 710	1950 770	1885 780	1735 735
	HIGH (450 CFM/TON)	OFF	OFF	ON	OFF	CFM WATTS	2190 835	2150 870	2075 890	1905 800	1735 735

NOTES:

- * First Letter may be "A" or "T"
- ** Factory setting
- Continuous Fan Setting: Heating or Cooling airflow is approximately 50% of selected Cooling value.
- LOW 350 cfm/ton is recommended for Variable Speed application for COMFORT & HUMID CLIMATE setting; NORMAL is 400 cfm/ton; HIGH 450 cfm/ton is for DRY CLIMATE setting

Service Facts

*DD2B060A9V3VA FURNACE HEATING AIRFLOW (CFM) AND POWER (WATTS) VS. EXTERNAL STATIC PRESSURE WITH FILTER									
	AIRFLOW SETTING	DIP SWITCH SETTING			EXTERNAL STATIC PRESSURE				
		S4-3	S4-4		0.1	0.3	0.5	0.7	0.9
HEATING 1ST STAGE	LOW	ON	ON	CFM TEMP. RISE WATTS	547 53 48	593 49 80	571 51 107	567 51 143	544 53 170
	MEDIUM **	ON	OFF	CFM TEMP. RISE WATTS	658 44 65	664 44 92	658 44 122	658 44 155	652 44 197
	HIGH	OFF	OFF	CFM TEMP. RISE WATTS	735 39 75	761 38 120	761 38 155	764 38 190	762 38 230
HEATING 2ND STAGE	LOW	ON	ON	CFM TEMP. RISE WATTS	743 60 75	777 57 120	775 57 155	783 57 195	772 58 230
	MEDIUM **	ON	OFF	CFM TEMP. RISE WATTS	874 51 105	887 50 150	881 50 185	894 50 230	894 50 270
	HIGH	OFF	OFF	CFM TEMP. RISE WATTS	996 45 143	1013 44 192	1041 43 250	1058 42 307	1069 42 337

*DD2B060A9V3VA FURNACE COOLING AIRFLOW (CFM) AND POWER (WATTS) VS. EXTERNAL STATIC PRESSURE WITH FILTER											
OUTDOOR UNIT SIZE (TONS)	AIRFLOW SETTING	DIP SWITCH SETTING					EXTERNAL STATIC PRESSURE				
		S3-1	S3-2	S3-3	S3-4		0.1	0.3	0.5	0.7	0.9
1.5	LOW (350 CFM/ TON)	ON	ON	OFF	ON	CFM WATTS	533 45	563 75	546 100	534 130	515 160
	NORMAL (400 CFM/ TON)	ON	ON	OFF	OFF	CFM WATTS	609 55	627 90	624 115	606 150	607 180
	HIGH (450 CFM/ TON)	ON	ON	ON	OFF	CFM WATTS	664 65	683 95	690 135	687 165	680 200
2.0	LOW (350 CFM/ TON)	OFF	ON	OFF	ON	CFM WATTS	693 65	714 105	708 135	706 170	712 210
	NORMAL (400 CFM/ TON)	OFF	ON	OFF	OFF	CFM WATTS	780 85	821 130	813 165	810 205	816 245
	HIGH (450 CFM/ TON)	OFF	ON	ON	OFF	CFM WATTS	886 110	896 150	901 200	925 250	930 285
2.5	LOW (350 CFM/ TON)	ON	OFF	OFF	ON	CFM WATTS	865 105	882 145	869 185	884 275	885 265
	NORMAL (400 CFM/ TON)	ON	OFF	OFF	OFF	CFM WATTS	977 135	983 180	1014 235	1035 290	1019 330
	HIGH (450 CFM/ TON)	ON	OFF	ON	OFF	CFM WATTS	1097 170	1125 235	1155 305	1169 350	1169 405
3.0 **	LOW (350 CFM/ TON)	OFF	OFF	OFF	ON	CFM WATTS	1006 145	1034 200	1056 255	1072 315	1067 352
	NORMAL ** (400 CFM/ TON)	OFF	OFF	OFF	OFF	CFM WATTS	1169 215	1202 265	1226 355	1221 390	1217 440
	HIGH (450 CFM/ TON)	OFF	OFF	ON	OFF	CFM WATTS	1313 290	1339 370	1360 425	1369 500	1357 525

NOTES:

- *FIRST LETTER MAY BE "A" OR "T"
- **FACTORY SETTING.
- CONTINUOUS FAN SETTING: HEATING OR COOLING AIRFLOW IS APPROXIMATELY 50% OF SELECTED COOLING VALUE.
- LOW 350 CFM/TON IS RECOMMENDED FOR VARIABLE SPEED APPLICATION FOR COMFORT & HUMID CLIMATE SETTING:
NORMAL IS 400 CFM/TON: HIGH 450 CFM/TON IS FOR DRY CLIMATE SETTING.

Service Facts

*DD2B080A9V3VA FURNACE HEATING AIRFLOW (CFM) AND POWER (WATTS) VS. EXTERNAL STATIC PRESSURE WITH FILTER									
	AIRFLOW SETTING	DIP SWITCH SETTING			EXTERNAL STATIC PRESSURE				
		S4-3	S4-4		0.1	0.3	0.5	0.7	0.9
HEATING 1ST STAGE	LOW	ON	ON	CFM TEMP. RISE WATTS	775 50 85	750 51 110	700 55 140	685 56 170	680 57 185
	MEDIUM **	ON	OFF	CFM TEMP. RISE WATTS	865 45 110	840 46 140	820 47 175	795 48 210	770 50 235
	HIGH	OFF	OFF	CFM TEMP. RISE WATTS	1010 38 160	980 39 190	970 40 230	940 41 260	915 42 285
HEATING 2ND STAGE	LOW	ON	ON	CFM TEMP. RISE WATTS	1080 55 180	1060 56 220	1035 57 255	1010 59 285	995 60 325
	MEDIUM **	ON	OFF	CFM TEMP. RISE WATTS	1190 50 245	1190 50 290	1170 51 330	1155 51 370	1140 52 410
	HIGH	OFF	OFF	CFM TEMP. RISE WATTS	1345 44 330	1335 44 380	1320 45 425	1310 45 475	1275 46 505

*DD2B080A9V3VA FURNACE COOLING AIRFLOW (CFM) AND POWER (WATTS) VS. EXTERNAL STATIC PRESSURE WITH FILTER											
OUTDOOR UNIT SIZE (TONS)	AIRFLOW SETTING	DIP SWITCH SETTING					EXTERNAL STATIC PRESSURE				
		S3-1	S3-2	S3-3	S3-4		0.1	0.3	0.5	0.7	0.9
2.5	LOW (350 CFM/TON)	OFF	ON	OFF	ON	CFM WATTS	840 105	830 135	830 160	815 220	750 225
	NORMAL (400 CFM/TON)	OFF	ON	OFF	OFF	CFM WATTS	970 140	950 170	940 210	925 245	900 270
	HIGH (450 CFM/TON)	OFF	ON	ON	OFF	CFM WATTS	1085 185	1060 220	1045 260	1015 300	1000 325
3.0	LOW (350 CFM/TON)	ON	OFF	OFF	ON	CFM WATTS	1015 155	995 190	990 230	970 260	920 285
	NORMAL (400 CFM/TON)	ON	OFF	OFF	OFF	CFM WATTS	1150 215	1140 250	1120 305	1100 335	1085 370
	HIGH (450 CFM/TON)	ON	OFF	ON	OFF	CFM WATTS	1290 300	1290 340	1270 390	1260 425	1235 475
3.5 **	LOW (350 CFM/TON)	OFF	OFF	OFF	ON	CFM WATTS	1160 220	1150 265	1140 320	1115 345	1100 385
	NORMAL ** (400 CFM/TON)	OFF	OFF	OFF	OFF	CFM WATTS	1355 330	1340 380	1330 425	1320 470	1280 510
	HIGH (450 CFM/TON)	OFF	OFF	ON	OFF	CFM WATTS	1360 330	1360 380	1315 425	1320 470	1280 510

NOTES:

- * First letter may be "A" or "T"
- ** Factory setting
- Continuous Fan Setting: Heating or Cooling airflow is approximately 50% of selected Cooling value.
- LOW 350 cfm/ton is recommended for Variable Speed application for COMFORT & HUMID CLIMATE setting; NORMAL is 400 cfm/ton; HIGH 450 cfm/ton is for DRY CLIMATE setting

Service Facts

*DD2C100A9V5VA FURNACE HEATING AIRFLOW (CFM) AND POWER (WATTS) VS. EXTERNAL STATIC PRESSURE WITH FILTER									
	AIRFLOW SETTING	DIP SWITCH SETTING			EXTERNAL STATIC PRESSURE				
		S4-3	S4-4		0.1	0.3	0.5	0.7	0.9
HEATING 1ST STAGE	LOW	ON	ON	CFM TEMP. RISE WATTS	890 54 87	870 55 120	855 56 160	850 57 200	825 58 250
	MEDIUM **	ON	OFF	CFM TEMP. RISE WATTS	1100 44 135	1090 44 175	1080 45 225	1070 45 260	1070 45 320
	HIGH	OFF	OFF	CFM TEMP. RISE WATTS	1270 38 195	1290 37 260	1295 37 315	1300 37 365	1300 37 425
HEATING 2ND STAGE	LOW	ON	ON	CFM TEMP. RISE WATTS	1230 60 180	1220 61 220	1250 59 290	1255 59 345	1275 58 410
	MEDIUM **	ON	OFF	CFM TEMP. RISE WATTS	1520 49 295	1550 48 385	1560 47 460	1555 48 525	1530 48 565
	HIGH	OFF	OFF	CFM TEMP. RISE WATTS	1820 41 475	1825 41 570	1825 41 625	1800 41 685	1740 43 695

*DD2C100A9V5VA FURNACE COOLING AIRFLOW (CFM) AND POWER (WATTS) VS. EXTERNAL STATIC PRESSURE WITH FILTER											
OUTDOOR UNIT SIZE (TONS)	AIRFLOW SETTING	DIP SWITCH SETTING					EXTERNAL STATIC PRESSURE				
		S3-1	S3-2	S3-3	S3-4		0.1	0.3	0.5	0.7	0.9
3.0	LOW (350 CFM/TON)	ON	ON	OFF	ON	CFM WATTS	1025 125	1050 165	1035 195	1030 250	1005 285
	NORMAL (400 CFM/TON)	ON	ON	OFF	OFF	CFM WATTS	1185 165	1180 210	1180 250	1190 315	1190 365
	HIGH (450 CFM/TON)	ON	ON	ON	OFF	CFM WATTS	1300 200	1345 280	1355 325	1375 405	1370 450
3.5	LOW (350 CFM/TON)	OFF	ON	OFF	ON	CFM WATTS	1195 165	1185 215	1200 270	1200 320	1190 370
	NORMAL (400 CFM/TON)	OFF	ON	OFF	OFF	CFM WATTS	1360 230	1390 315	1425 380	1420 430	1420 495
	HIGH (450 CFM/TON)	OFF	ON	ON	OFF	CFM WATTS	1560 320	1595 425	1595 460	1595 540	1570 585
4.0	LOW (350 CFM/TON)	ON	OFF	OFF	ON	CFM WATTS	1350 235	1385 300	1410 375	1420 425	1410 495
	NORMAL (400 CFM/TON)	ON	OFF	OFF	OFF	CFM WATTS	1575 340	1615 420	1625 495	1610 545	1585 595
	HIGH (450 CFM/TON)	ON	OFF	ON	OFF	CFM WATTS	1800 480	1795 555	1790 620	1760 670	1690 675
5.0 **	LOW (350 CFM/TON)	OFF	OFF	OFF	ON	CFM WATTS	1745 440	1760 515	1755 595	1735 640	1670 660
	NORMAL ** (400 CFM/TON)	OFF	OFF	OFF	OFF	CFM WATTS	2010 630	2000 700	1940 745	1865 740	1760 725
	HIGH (450 CFM/TON)	OFF	OFF	ON	OFF	CFM WATTS	2205 830	2130 835	2015 800	1890 760	1740 720

NOTES:

- * First letter may be "A" or "T"
- ** Factory setting
- Continuous Fan Setting: Heating or Cooling airflow is approximately 50% of selected Cooling value.
- LOW 350 cfm/ton is recommended for Variable Speed application for COMFORT & HUMID CLIMATE setting; NORMAL is 400 cfm/ton; HIGH 450 cfm/ton is for DRY CLIMATE setting

Service Facts

DD2D120A9V5VA FURNACE HEATING AIRFLOW (CFM) AND POWER (WATTS) VS. EXTERNAL STATIC PRESSURE WITH FILTER									
	AIRFLOW SETTING	DIP SWITCH SETTING			EXTERNAL STATIC PRESSURE				
		S4-3	S4-4		0.1	0.3	0.5	0.7	0.9
HEATING 1ST STAGE	LOW	ON	ON	CFM TEMP. RISE WATTS	970 60 85	990 58 140	980 59 180	955 61 210	930 62 255
	MEDIUM **	ON	OFF	CFM TEMP. RISE WATTS	1120 52 120	1140 51 170	1115 52 215	1120 52 270	1120 52 315
	HIGH	OFF	OFF	CFM TEMP. RISE WATTS	1240 47 150	1240 47 210	1240 47 250	1240 47 300	1240 47 360
HEATING 2ND STAGE	LOW	ON	ON	CFM TEMP. RISE WATTS	1360 65 190	1380 64 250	1400 63 315	1425 62 400	1430 62 430
	MEDIUM **	ON	OFF	CFM TEMP. RISE WATTS	1570 57 275	1620 55 370	1640 54 440	1650 54 480	1635 54 560
	HIGH	OFF	OFF	CFM TEMP. RISE WATTS	1720 52 360	1735 51 425	1760 51 515	1760 51 585	1760 51 650

DD2D120A9V5VA FURNACE COOLING AIRFLOW (CFM) AND POWER (WATTS) VS. EXTERNAL STATIC PRESSURE WITH FILTER											
OUTDOOR UNIT SIZE (TONS)	AIRFLOW SETTING	DIP SWITCH SETTING					EXTERNAL STATIC PRESSURE				
		S3-1	S3-2	S3-3	S3-4		0.1	0.3	0.5	0.7	0.9
3.5	LOW (350 CFM/TON)	OFF	ON	OFF	ON	CFM WATTS	1200 150	1200 185	1185 235	1210 290	1210 350
	NORMAL (400 CFM/TON)	OFF	ON	OFF	OFF	CFM WATTS	1355 190	1400 265	1420 335	1445 385	1445 440
	HIGH (450 CFM/TON)	OFF	ON	ON	OFF	CFM WATTS	1535 255	1580 345	1600 415	1620 490	1600 530
4.0	LOW (350 CFM/TON)	ON	OFF	OFF	ON	CFM WATTS	1350 190	1370 250	1400 320	1415 385	1420 445
	NORMAL (400 CFM/TON)	ON	OFF	OFF	OFF	CFM WATTS	1570 275	1600 350	1630 425	1640 500	1630 560
	HIGH (450 CFM/TON)	ON	OFF	ON	OFF	CFM WATTS	1800 400	1800 450	1815 540	1820 610	1810 670
5.0 **	LOW (350 CFM/TON)	OFF	OFF	OFF	ON	CFM WATTS	1725 350	1750 440	1770 500	1790 580	1775 650
	NORMAL ** (400 CFM/TON)	OFF	OFF	OFF	OFF	CFM WATTS	1970 515	2015 615	2035 700	2010 775	1960 800
	HIGH (450 CFM/TON)	OFF	OFF	ON	OFF	CFM WATTS	2260 730	2250 830	2215 885	2100 860	1975 810

NOTES:

- * First Letter may be "A" or "T"
- ** Factory setting
- Continuous Fan Setting: Heating or Cooling airflow is approximately 50% of selected Cooling value.
- LOW 350 cfm/ton is recommended for Variable Speed application for COMFORT & HUMID CLIMATE setting; NORMAL is 400 cfm/ton; HIGH 450 cfm/ton is for DRY CLIMATE setting

Service Facts

The following warning complies with State of California law, Proposition 65.

WARNING

This product contains fiberglass wool insulation!

Fiberglass dust and ceramic fibers are believed by the State of California to cause cancer through inhalation. Glasswool fibers may also cause respiratory, skin, or eye irritation.

PRECAUTIONARY MEASURES

- Avoid breathing fiberglass dust.
- Use a NIOSH approved dust/mist respirator.
- Avoid contact with the skin or eyes. Wear long-sleeved, loose-fitting clothing, gloves, and eye protection.
- Wash clothes separately from other clothing: rinse washer thoroughly.
- Operations such as sawing, blowing, tear-out, and spraying may generate fiber concentrations requiring additional respiratory protection. Use the appropriate NIOSH approved respirator in these situations.

FIRST AID MEASURES

- Eye Contact** – Flush eyes with water to remove dust. If symptoms persist, seek medical attention.
- Skin Contact** – Wash affected areas gently with soap and warm water after handling.

* The diagnostics will indicate the specific fault through the following code:

GREEN LED FLASH	AMBER LED FLASH	RED LED FLASH	ERROR
		1	Flame Sensed when no flame should be present
		2	Pressure switch stuck closed
		3	1st stage pressure switch is open / not closing
		4	Open thermal limit or open rollout
		5	Open low voltage fuse
		6	1st stage pressure switch opened 5 times within one cycle--1 hour lockout
		7	System lockout Retry
		8	System lockout Recycle
		9	Reverse polarity or poor grounding
		10	Gas valve energized without call for heat
		12	Ignitor relay failure internal in board. Replace IFC
		Solid	Gas valve relay failure internal in board. Replace IFC
		3 Double	2nd stage pressure switch open; system reverts back to 1st stage heat
	1		1st stage call for heat
	2		2nd stage call for heat
	3		W2 call present without W1
	4		Y call present without G
	Rapid		Low flame sense current
1			Standby mode or call for cooling

Troubleshooting and Additional Information

Board layout.

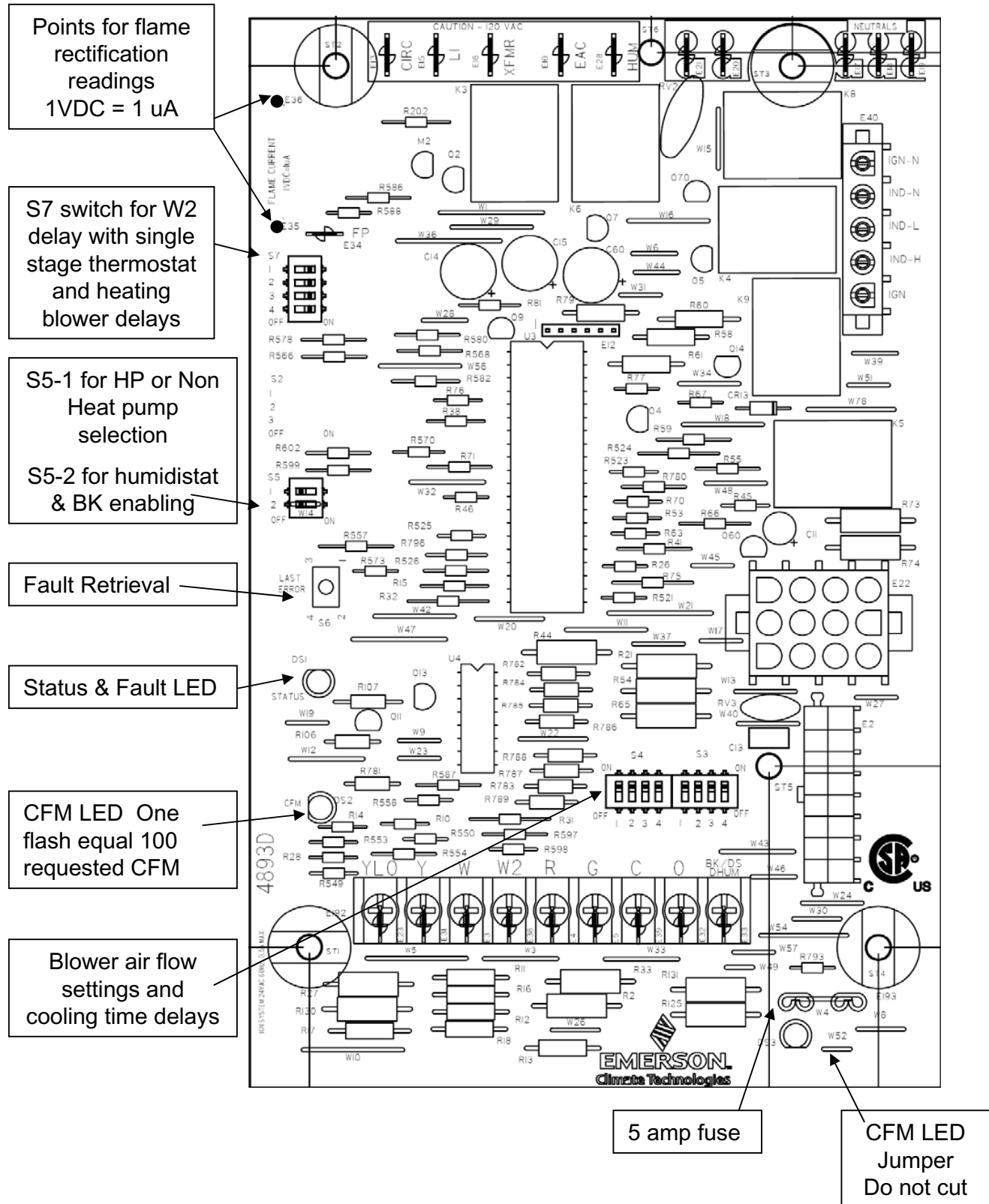

Service Facts

Board layout.

S7 switches 1 & 2 for W2 delay

Leave both switches off when using a 2-stage stat or enabling a W1 only call. See Troubleshooting for details on Auto

	Switch Settings		Options
	S7-1	S7-2	Time
W2 Delay S7-1, S7-2	Off	Off	Off
	On	Off	10 Minutes*
	Off	On	Auto
	On	On	20 Minutes

S7 switches 3 & 4 for blower delay in heating

	S7-3	S7-4	Time
	Heat Off Delay S7-3, S7-4	Off	Off
Off		On	120 Secs
On		Off	150 Secs
On		On	180 Secs

S5 switches 1 & 2

HEAT PUMP S5-1	ON	HEAT/COOL *
	OFF	HEAT PUMP
DE-HUMIDIFIER S5-2	ON	NOT INSTALLED*
	OFF	INSTALLED

* FACTORY SETTING

*Factory Settings

S3-1 & S3-2 control system tonnage. These switches configure air flow to match the tonnage of the condenser.

Reference door panel or blower performance tables for settings

S3-3 & S3-4 control CFM per ton

	S3-3	S3-4
Low (350 CFM/Ton)	OFF	ON
Normal (400 CFM/ton)	OFF	OFF
High (450 CFM/ton)	ON	OFF

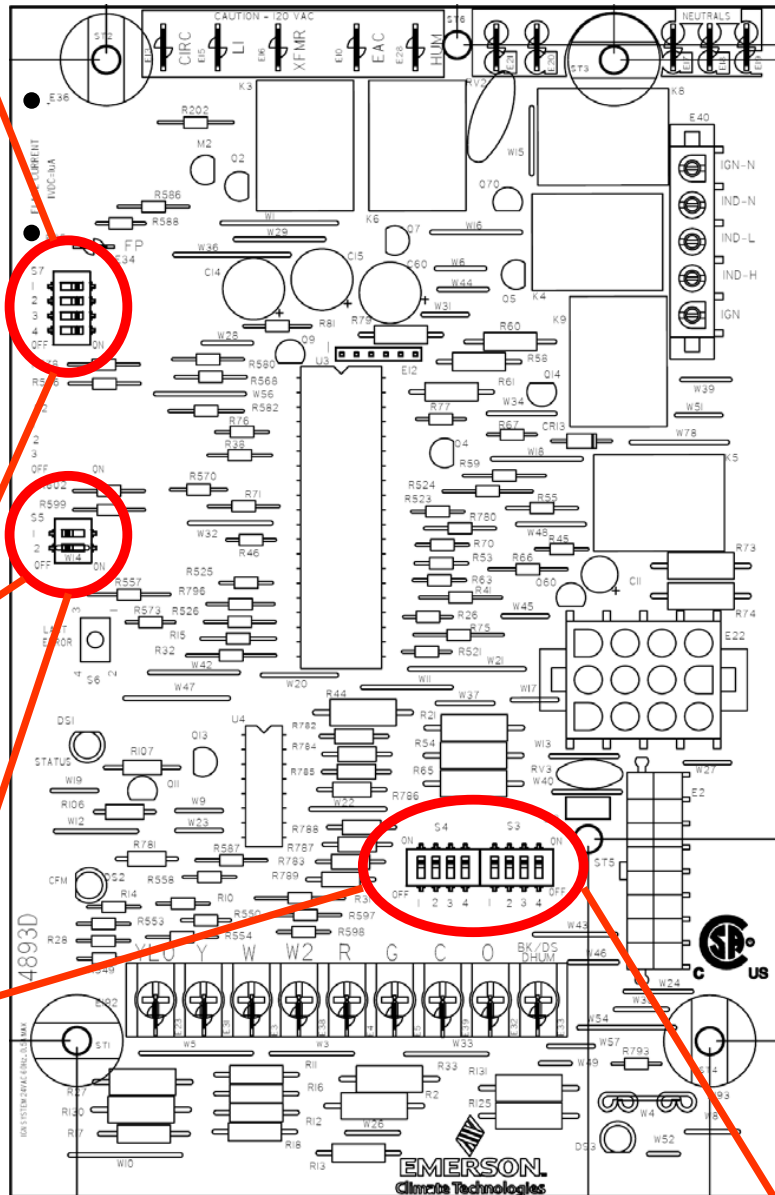

COOLING OFF - DELAY OPTIONS

SWITCH SETTINGS	SELECTION	NOMINAL AIRFLOW
S4-1 - OFF S4-2 - OFF	NONE	SAME
S4-1 - ON S4-2 - OFF	1.5 MINUTES	100% *
S4-1 - OFF S4-2 - ON	3 MINUTES	50%
S4-1 - ON S4-2 - ON	**	50 - 100%

* - This setting is equivalent to BAY24X045 relay benefit

** - This selection provides **ENHANCED MODE**, which is a ramping up and ramping down of the blower speed to provide improved comfort, quietness, and potential energy savings. See Wiring Diagram notes on the unit or in the Service Facts for complete wiring setup for **ENHANCED MODE**. The graph which follows, shows the ramping process.

S4-3 & S4-4 control blower heating speeds. Reference blower tables for required heating air flow.

Fault Code Retrieval

The IFC has the ability to store fault codes in memory. To retrieve previous faults, push and release the last error button for 1 to 5 seconds. The LED will flash up to five stored fault codes beginning with the most recent. There is a two second delay between the faults displayed. The LED will flash two green flashes if there are no fault codes in memory.

Fault Code Reset

Push and hold the last error button between 5 and 10 seconds to clear all faults from memory. The LED will flash three green flashes to confirm that memory has been cleared.

BK Feature

Enabling the BK feature is done through the S5-2 switch on the IFC. The switch comes in the de-activated "ON" position from the factory. Move this switch to the "OFF" position to enable the BK function of the board. Do not cut any jumpers on this board.

The BK feature is used for blower modulation when using a humidistat for de-humidification, a two step scroll compressor system, a 402 thermostat (with BK enabled), or residential zoning.

A jumper must be placed between R & O on the low voltage terminal board to engage the BK circuit

W2 staging time delay options with single stage stat

The auto mode can be used when employing a single stage heating thermostat. This mode allows the furnace to move into second stage based on the past three hour duty cycle of the furnace.

*A furnace running in mild conditions will have a low duty cycle and a second stage delay of 10 to 12 minutes.

*A furnace running in normal conditions will have an average duty cycle and a second stage delay of 5 to 7 minutes.

*A furnace running in cold conditions will have a high duty cycle and a second stage delay of only 1 to 3 minutes.

Leave S7-1 & S7-2 to the off position when using a 2-stage thermostat.

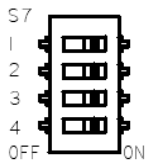

	Switch Settings		Options
	S7-1	S7-2	Time
W2 Delay S7-1, S7-2	Off	Off	Off
	On	Off	10 Minutes*
	Off	On	Auto
	On	On	20 Minutes

The 50V51 Control board uses a 115 Silicone Nitride Igniter. This control board does not reduce the voltage to the igniter as other boards do. Do not use lower voltage igniters as replacement options. Only use the OEM igniter for replacement.

Service Facts

NOTICE: Since the manufacturer has a policy of continuous product and product data improvement, it reserves the right to change design and specifications without notice.