

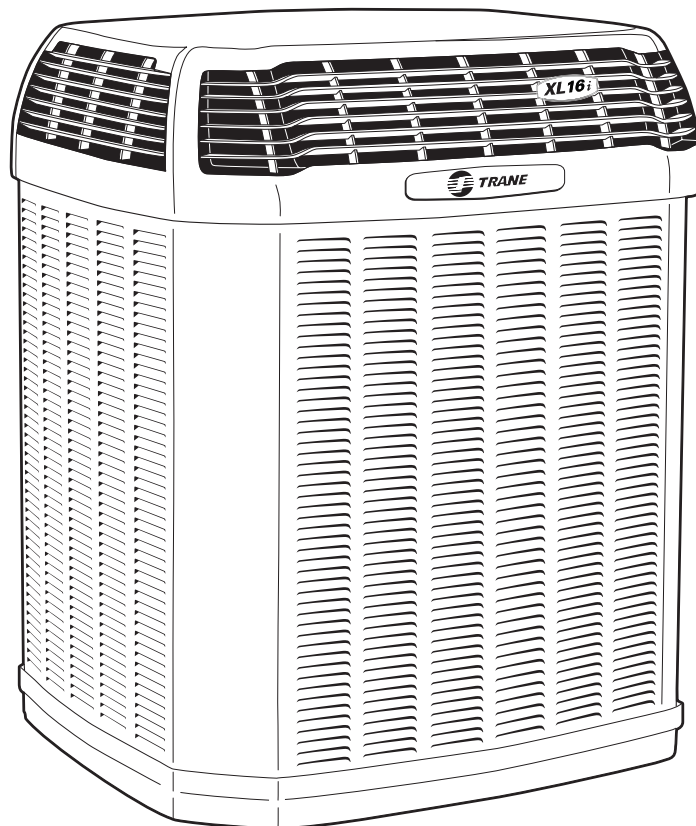

Split System Heat Pump Product Data

XL16i
4TWX6024, 036, 048 & 060E

2, 3, 4 & 5 Tons



PUB. NO. 22-1754-17



Features and Benefits

- **CLIMATUFF™** 2-stage scroll compressor
- Efficiency up to **18.0 SEER** and **9.0 HSPF**
- All Aluminum **SPINE FIN™** coil
- **WEATHERGUARD™ II** top shields unit
- **DURATUFF™** weather proof and rust proof base
- **COMFORT "R"™** mode approved for better comfort indoors
- **QUICK-SESS™** cabinet, service access and refrigerant connections with full coil protection
- **WEATHERGUARD™** fasteners
- Glossy corrosion resistant finish tarpaulin gray cabinet with anthracite gray top
- Internal compressor high/low pressure & temperature protection
- Liquid line filter/drier
- Low sound with advanced variable speed fan motor
- Service valve cover
- R-410A refrigerant
- From 70 to 100% capacity modulation
- 100% run test in the factory
- Low ambient cooling to 55° as shipped
- **Extended warranties available**

Contents

Features and Benefits	2
General Data	4
Product Specifications	4
A-weighted Sound Power Level [dB(A)]	4
Accessory Description and Usage	5
AHRI Standard Capacity Rating Conditions	5
Model Nomenclature	6
Electrical Data	7
Dimensions	10
Mechanical Specifications	11



General Data

Product Specifications

Model No. ①	4TWX6024E1	4TWX6036E1	4TWX6048E1	4TWX6060E1
Electrical Data V/Ph/Hz ②	230/1/60	230/1/60	230/1/60	230/1/60
Min Cir Ampacity	14	22	28	39
Max Fuse Size (Amps)	20	35	45	60
Compressor	CLIMATUFF® - SCROLL	CLIMATUFF® - SCROLL	CLIMATUFF® - SCROLL	CLIMATUFF® - SCROLL
RL AMPS - LR AMPS	10.3 - 52	16.7 - 82	21.2 - 104	28.8 - 152.9
Outdoor Fan FL Amps	0.74	0.74	1.00	2.80
Fan HP	1/8	1/8	1/5	1/3
Fan Dia (inches)	27.6	27.6	27.6	27.6
Coil	Spine Fin™	Spine Fin™	Spine Fin™	Spine Fin™
Refrigerant R-410A	10/3-LB/OZ	10/8-LB/OZ	12/9-LB/OZ	13/3-LB/OZ
Line Size - (in.) O.D. Gas ③	5/8	3/4	7/8	1-1/8
Line Size - (in.) O.D. Liquid ③	3/8	3/8	3/8	3/8
Dimensions H x W x D (Crated)	53.4 x 35.1 x 38.7	57.4 x 35.1 x 38.7	57.4 x 35.1 x 38.7	57.4 x 35.1 x 38.7
Weight - Shipping	305	307	360	361
Weight - Net	257	257	310	311
Start Components	YES	NO	NO	NO
Sound Enclosure	NO	NO	NO	NO
Compressor Sump Heat	YES	YES	YES	YES
Optional Accessories: ④				
Rubber Isolator Kit	BAYISLT101	BAYISLT101	BAYISLT101	BAYISLT101
Snow Leg - Base & Cap 4" High	BAYLEGS002	BAYLEGS002	BAYLEGS002	BAYLEGS002
Snow Leg - 4" Extension	BAYLEGS003	BAYLEGS003	BAYLEGS003	BAYLEGS003
Hard Start Kit Scroll		BAYKSKT260	BAYKSKT260	BAYKSKT260
Extreme Condition Mounting Kit	BAYECMT004	BAYECMT004	BAYECMT004	BAYECMT004
Vertical Discharge Air Kit Base 4	BAYVDTA003	BAYVDTA004	BAYVDTA004	BAYVDTA004
Auto Charge Solenoid Kit	BAYCAKT001	BAYCAKT001	BAYCAKT001	BAYCAKT001
Refrigerant Lineset ⑤	TAYREFLN9*	TAYREFLN7*	TAYREFLN3*	TAYREFLN4*

① Certified in accordance with the Air-Source Unitary Heat Pump Equipment certification program which is based on AHRI Standard 210/240.

② Calculated in accordance with N.E.C. Only use HACR circuit breakers or fuses.

③ Standard line lengths - 60'. Standard lift - 25' Suction and Liquid line.

For Greater lengths and lifts refer to refrigerant piping software Pub# 32-3312-0†. (†denotes latest revision)

④ For accessory description and usage, see page 5.

⑤ * = 15, 20, 25, 30, 40 and 50 foot lineset available.

A-weighted Sound Power Level [dB(A)]

MODEL	SOUND POWER LEVEL [dB(A)]	A-WEIGHTED FULL OCTAVE SOUND POWER LEVEL dB - [dB(A)]							
		63	125	250	500	1000	2000	4000	8000
4TWX6024E	72	40.4	50.8	53.7	59.9	62.2	57.9	56.1	48.4
4TWX6036E	72	39.3	49.6	55.7	60.5	62.9	57.7	54.7	47.3
4TWX6048E	72	42	57.3	56.6	64	63.3	57.2	53.5	46.2
4TWX6060E	74	31.9	58.9	57.1	64.8	66.4	59.8	55.9	51.2

Note: Rated in accordance with AHRI Standard 270-2008.

General Data

Accessory Description and Usage

Rubber Isolators — 5 rubber donuts to isolate condensing unit from mounting frame or pad. Use on any application where sound transmission needs to be minimized.

Extreme Conditions Mounting Kit — Bracket kits to securely mount condensing unit to a frame or pad without removing any panels. Use in areas with high winds, or on commercial rooftops, etc.

Low Ambient Cooling — For low ambient cooling below 55° see Application Guide APP-APG013-EN.

AHRI Standard Capacity Rating Conditions

AHRI STANDARD 210/240 RATING CONDITIONS —

- (A) Cooling 80°F DB, 67°F WB air entering indoor coil, 95°F DB air entering outdoor coil.
- (B) High Temperature Heating 47°F DB, 43°F WB air entering outdoor coil, 70°F DB air entering indoor coil.
- (C) Low Temperature Heating 17°F DB, 15°F WB air entering outdoor coil, 70°F DB air entering indoor coil.
- (D) Rated indoor airflow for heating is the same as for cooling.

AHRI STANDARD 270 RATING CONDITIONS — (Noise rating numbers are determined with the unit in cooling operation.) Standard Noise Rating number is at 95°F outdoor air.





Model Nomenclature

Outdoor Units

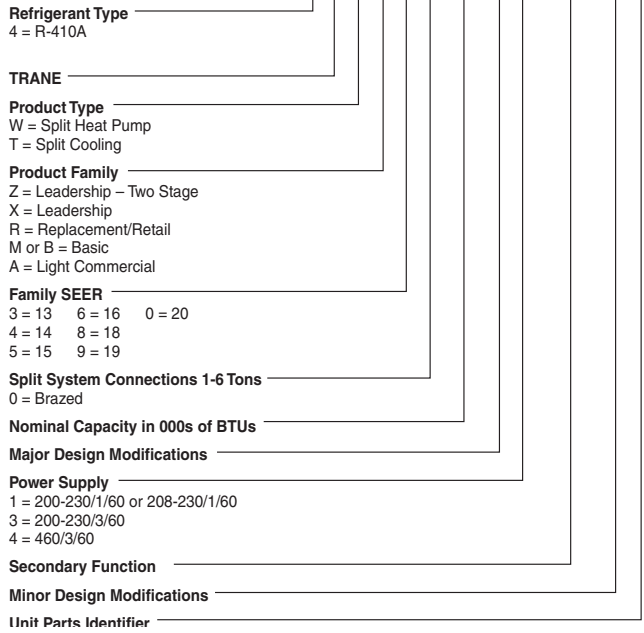

Air Handlers – Residential

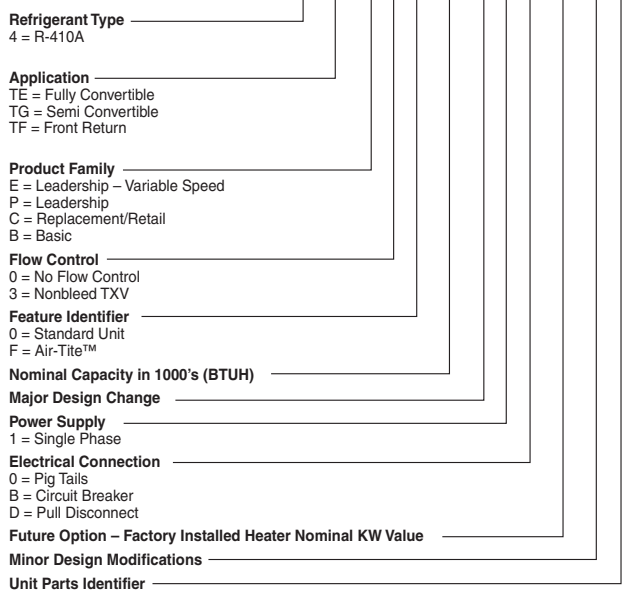

NOTE: There will be a phase-in of new model numbers for new air handlers over next 2 years.

Gas Furnaces

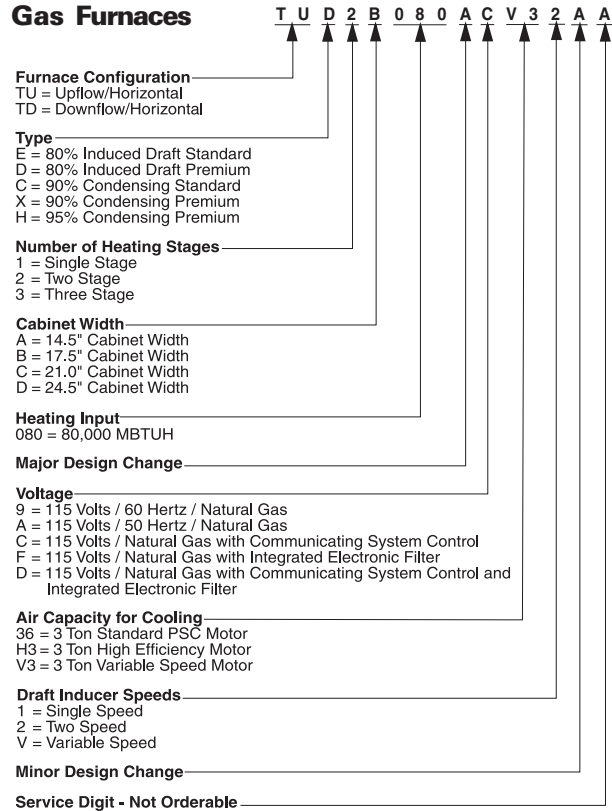

Coils – Residential

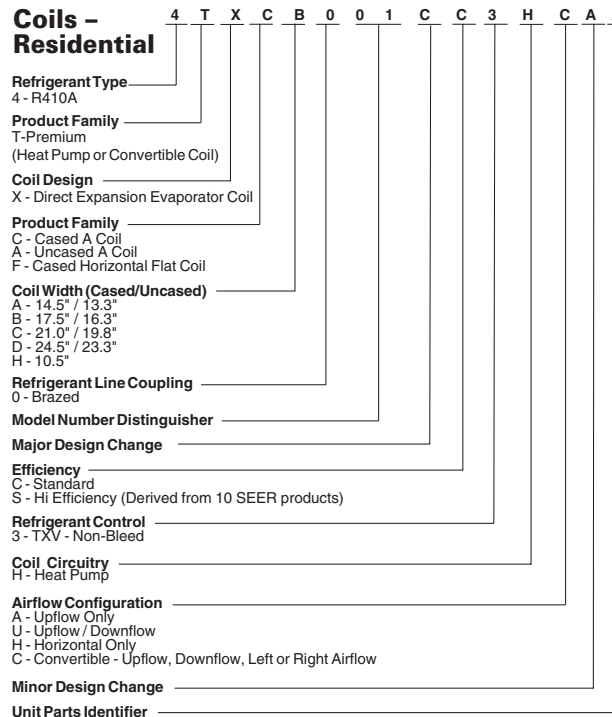

Electrical Data

Schematic Diagrams

(SEE LEGEND)

4Twx6024

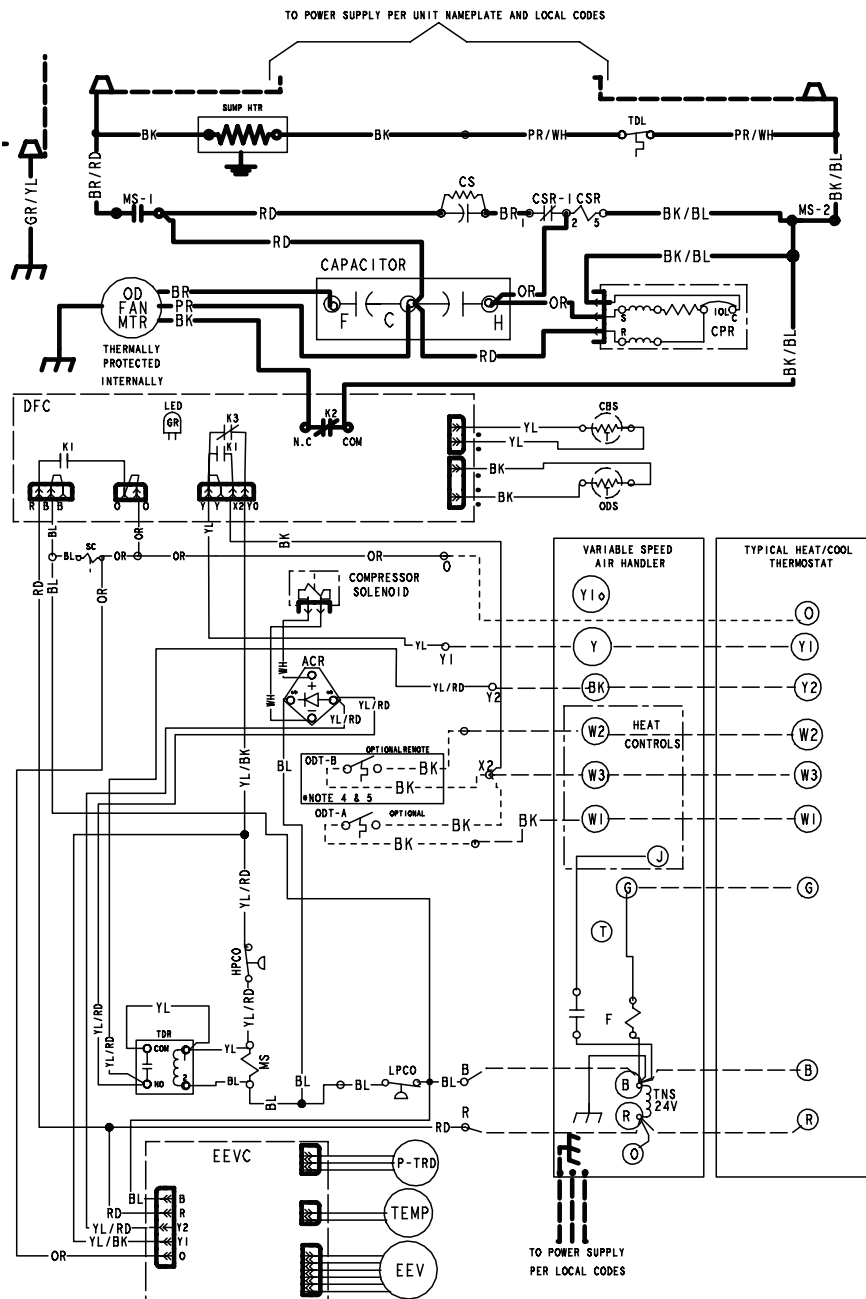

- ACR A/C RECTIFIER
- CBS COIL BOTTOM SENSOR
- CF FAN CAPACITOR
- CN WIRE CONNECTOR
- CR COMPRESSOR
- CSR RUN CAPACITOR
- CS STARTING CAPACITOR
- CSR CAPACITOR SWITCHING RELAY
- DFC DEFROST CONTROL
- EEV ELECTRONIC EXP VALVE
- EEVC ELECTRONIC EXP VALVE CONTROL
- F INDOOR FAN RELAY
- HPCO HIGH PRESSURE CUTOFF SWITCH
- IOL INTERNAL OVERLOAD PROTECTOR
- LPCCO LOW PRESSURE CUTOFF SWITCH
- MS COMPRESSOR MOTOR CONTACTOR
- ODA OUTDOOR ANTICIPATOR
- OFT OUTDOOR FAN THERMOSTAT
- ODT OUTDOOR THERMOSTAT
- ODT OUTDOOR THERMOSTAT
- P-TRD PRESSURE TRANSDUCER
- SC SWITCH OVER VALVE SOLENOID
- SM SYSTEM ON-OFF SWITCH
- TDL DISCHARGE LINE THERMOSTAT
- TDR TIME DELAY RELAY (60 SEC DELAY ON)
- TNS TRANSFORMER
- TEMP SENSOR, TEMPERATURE

WARNING

HAZARDOUS VOLTAGE!
DISCONNECT ALL ELECTRICAL POWER INCLUDING REMOTE DISCONNECTS BEFORE SERVICING.
Failure to disconnect power before servicing can cause severe personal injury or death.

CAUTION

USE COPPER CONDUCTORS ONLY!
UNIT TERMINALS ARE NOT DESIGNED TO ACCEPT OTHER TYPES OF CONDUCTORS.
Failure to do so may cause damage to the equipment.

NOTES:

1. BE SURE POWER SUPPLY AGREES WITH EQUIPMENT NAMEPLATE.
2. POWER WIRING AND GROUNDING OF EQUIPMENT MUST COMPLY WITH LOCAL CODES.
3. LOW VOLTAGE WIRING TO BE NO. 18 AWG MINIMUM CONDUCTOR.
4. ODT-B MUST BE SET LOWER THAN ODT-A
5. IF ODT-B IS NOT USED, CONNECT A JUMPER WIRE FROM W3 TO W2. IF ODT-A IS NOT USED, CONNECT A JUMPER WIRE FROM W2 TO W1.
6. IF ELECTRIC HEATER DOES NOT HAVE A 3RD CONTACTOR (CH), CONNECT A JUMPER WIRE FROM W3 TO W2. IF ELECTRIC HEATER DOES NOT HAVE A 2ND CONTACTOR (BH), CONNECT A JUMPER WIRE FROM W2 TO W1.
7. Y2 MUST BE CONNECTED TO VARIABLE SPEED AIR HANDLER TERMINAL W3 AS SHOWN, FOR PROPER INDOOR AIR FLOW DURING THE DEFROST CYCLE
8. BE SURE THE JUMPER BETWEEN R AND BK IS CUT OR REMOVED.
9. WITH O AND Y/Y2 ENERGIZED, INDOOR FAN IS AT 80% AIRFLOW.
10. WITH O, Y/Y2 AND BK ENERGIZED, INDOOR FAN IS AT 100% AIRFLOW.

FOR CANADIAN INSTALLATIONS
POUR INSTALLATIONS CANADIENNES

CAUTION: NOT SUITABLE FOR USE ON SYSTEMS EXCEEDING 150V-TO-GROUND
ATTENTION: NE CONVIENT PAS AUX INSTALLATIONS DE PLUS DE 150 V A LA TERRE

Electrical Data

Schematic Diagrams

(SEE LEGEND)

4TWX6036E

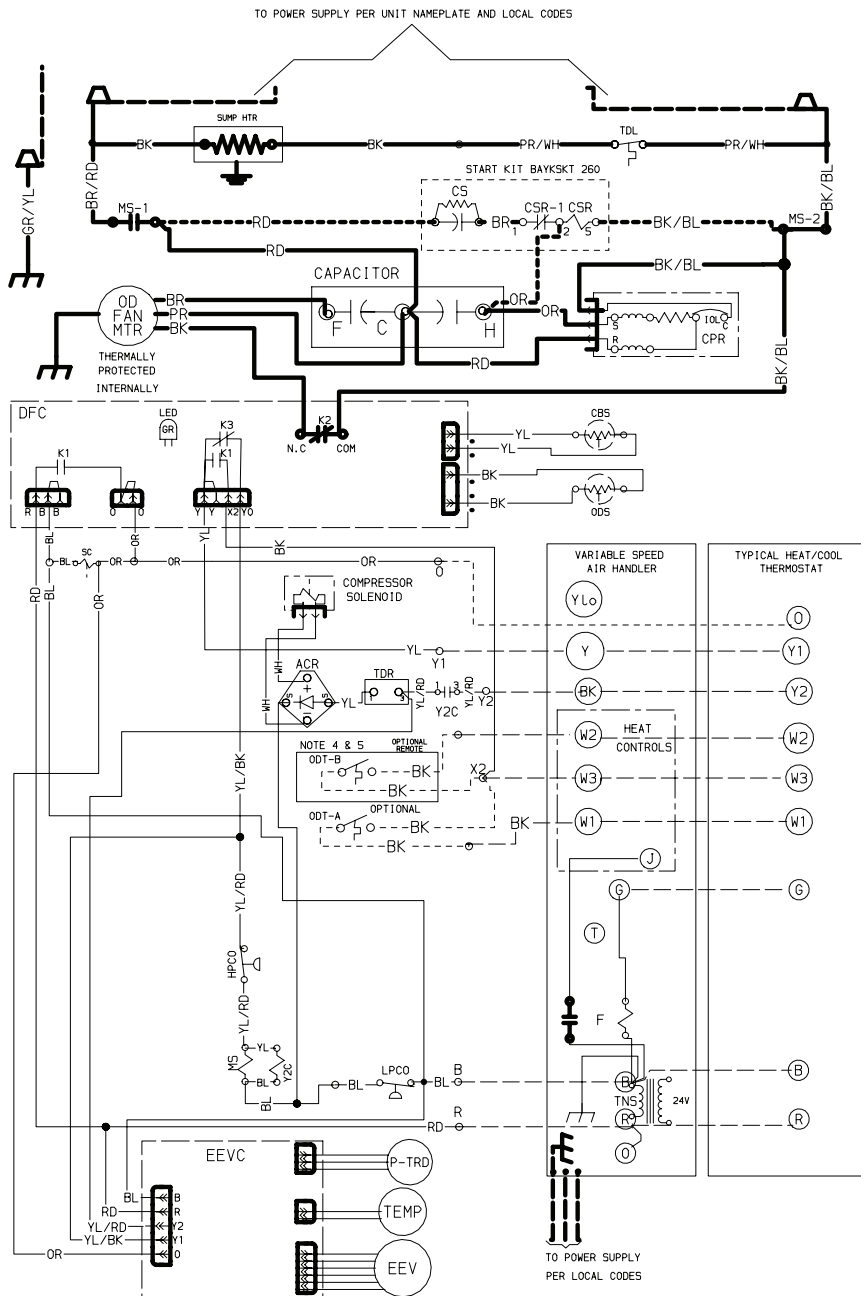

- ACR A/C RECTIFIER
- CBS COIL BOTTOM SENSOR
- CF FAN CAPACITOR
- CN WIRE CONNECTOR
- CPR COMPRESSOR
- CR RUN CAPACITOR
- CS STARTING CAPACITOR
- CSR CAPACITOR SWITCHING RELAY
- DFC DEFROST CONTROL
- EEVC ELECTRONIC EXP VALVE
- EEVC ELECTRONIC EXP VALVE CONTROL
- F INDOOR FAN RELAY
- HPCO HIGH PRESSURE CUTOFF SWITCH
- LOL INTERNAL OVERLOAD PROTECTOR
- LPCC LOW PRESSURE CUTOFF SWITCH
- MS COMPRESSOR MOTOR CONTACTOR
- ODA OUTDOOR ANTICIPATOR
- OFF OUTDOOR FAN THERMOSTAT
- ODS OUTDOOR TEMPERATURE SENSOR
- ODT OUTDOOR THERMOSTAT
- P-TRD PRESSURE TRANSDUCER
- SC SWITCH OVER VALVE SOLENOID
- SM SYSTEM ON-OFF SWITCH
- TDL DISCHARGE LINE THERMOSTAT
- TDR TIME DELAY RELAY (5 SEC DELAY ON)
- TNS TRANSFORMER
- TEMP SENSOR, TEMPERATURE
- Y2C HIGH CAPACITY CONTROL RELAY

⚠ WARNING

HAZARDOUS VOLTAGE!
DISCONNECT ALL ELECTRICAL POWER INCLUDING REMOTE DISCONNECTS BEFORE SERVICING.
Failure to disconnect power before servicing can cause severe personal injury or death.

⚠ CAUTION

USE COPPER CONDUCTORS ONLY!
UNIT TERMINALS ARE NOT DESIGNED TO ACCEPT OTHER TYPES OF CONDUCTORS. Failure to do so may cause damage to the equipment.

NOTES:

1. BE SURE POWER SUPPLY AGREES WITH EQUIPMENT NAMEPLATE.
2. POWER WIRING AND GROUNDING OF EQUIPMENT MUST COMPLY WITH LOCAL CODES.
3. LOW VOLTAGE WIRING TO BE NO. 18 AWG MINIMUM CONDUCTOR.
4. ODT-B MUST BE SET LOWER THAN ODT-A
5. IF ODT-B IS NOT USED, CONNECT A JUMPER WIRE FROM W3 TO W2. IF ODT-A IS NOT USED, CONNECT A JUMPER WIRE FROM W2 TO W1.
6. IF ELECTRIC HEATER DOES NOT HAVE A 3RD CONTACTOR (CH), CONNECT A JUMPER WIRE FROM W3 TO W2. IF ELECTRIC HEATER DOES NOT HAVE A 2ND CONTACTOR (BH), CONNECT A JUMPER WIRE FROM W2 TO W1.
7. X2 MUST BE CONNECTED TO VARIABLE SPEED AIR HANDLER TERMINAL W3 AS SHOWN, FOR PROPER INDOOR AIR FLOW DURING THE DEFROST CYCLE.
8. BE SURE THE JUMPER BETWEEN R AND BK IS CUT OR REMOVED.
9. WITH 0 AND Y/Y2 ENERGIZED, INDOOR FAN IS AT 80% AIRFLOW.
10. WITH 0, Y/Y2 AND BK ENERGIZED, INDOOR FAN IS AT 100% AIRFLOW.

FOR CANADIAN INSTALLATIONS
POUR INSTALLATIONS CANADIENNES

CAUTION: NOT SUITABLE FOR USE ON SYSTEMS EXCEEDING 150V-TO-GROUND
ATTENTION: NE CONVIENT PAS AUX INSTALLATIONS DE PLUS DE 150 V A LA TERRE

Electrical Data

Schematic Diagrams

(SEE LEGEND)

4TWX6048E

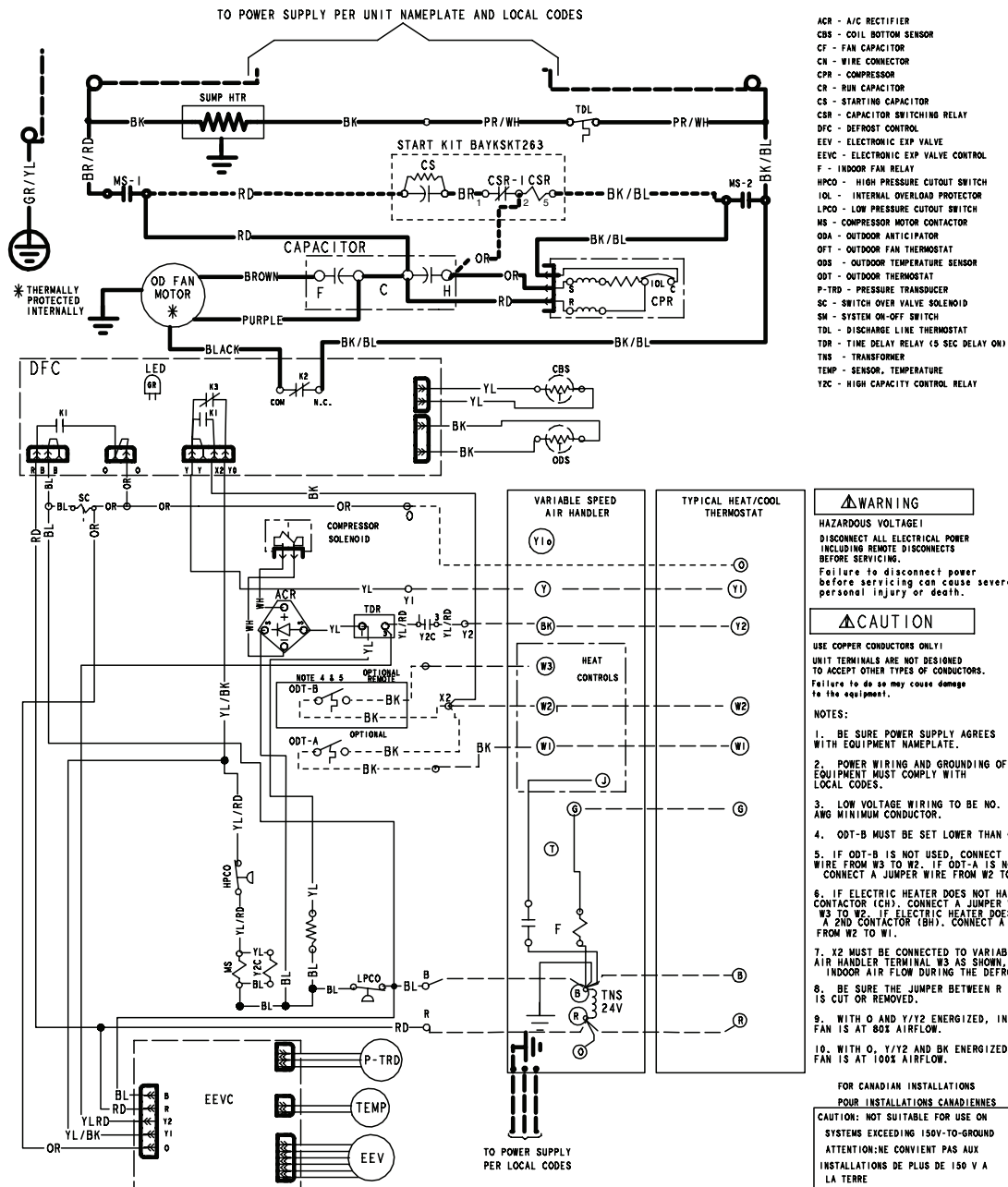

Electrical Data

Schematic Diagrams

(SEE LEGEND)

4TWX6060E

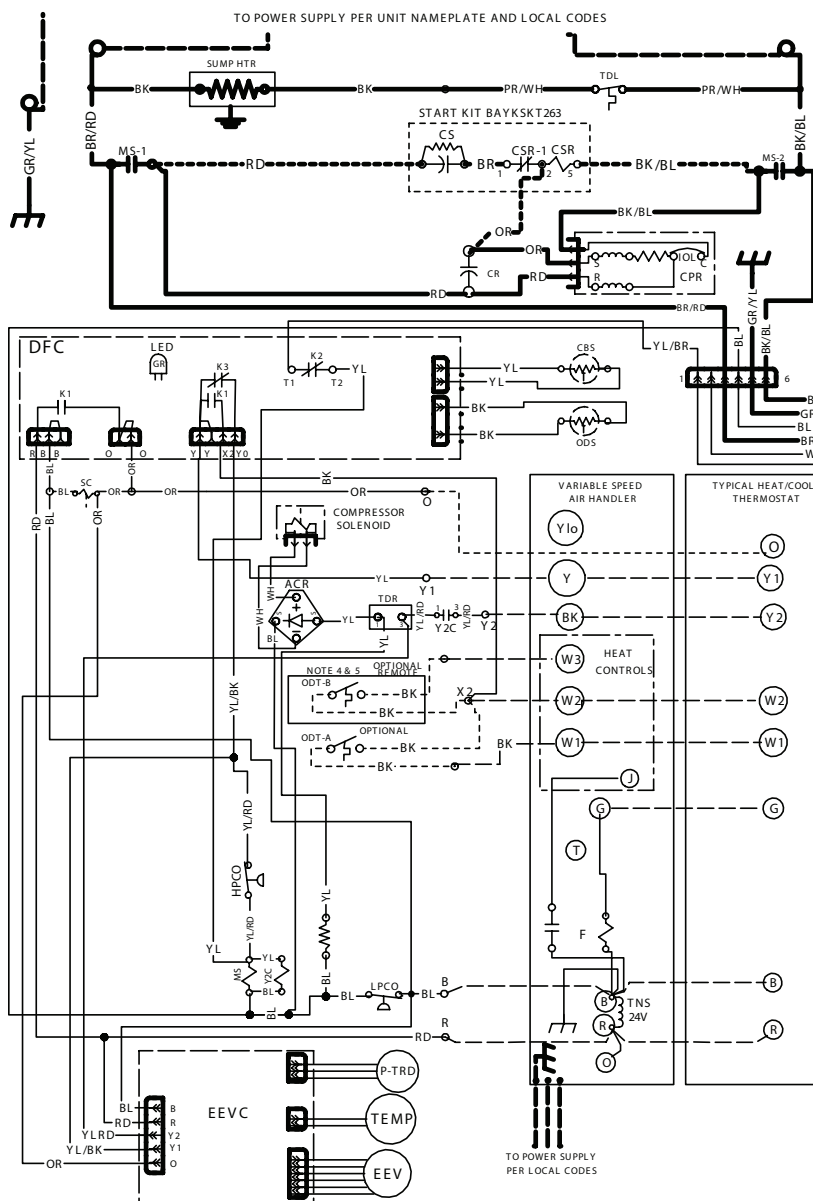

- ACR - A/C RECTIFIER
- CBS - COIL BOTTOM SENSOR
- CF - FAN CAPACITOR
- CN - WIRE CONNECTOR
- CPR - COMPRESSOR
- CR - RUN CAPACITOR
- CS - STARTING CAPACITOR
- CSR - CAPACITOR SWITCHING RELAY
- DFC - DEFROST CONTROL
- EEV - ELECTRONIC EXP VALVE
- EEVC - ELECTRONIC EXP VALVE CONTROL
- F - INDOOR FAN RELAY
- HPCO - HIGH PRESSURE CUTOFF SWITCH
- IOI - INTERNAL OVERLOAD PROTECTOR
- LPCO - LOW PRESSURE CUTOFF SWITCH
- MS - COMPRESSOR MOTOR CONTACTOR
- ODA - OUTDOOR ANTICIPATOR
- OFT - OUTDOOR FAN THERMOSTAT
- ODS - OUTDOOR TEMPERATURE SENSOR
- ODT - OUTDOOR THERMOSTAT
- P-TRD - PRESSURE TRANSDUCER
- SC - SWITCH DIVER VALVE SOLENOID
- SM - SYSTEM ON-OFF SWITCH
- TDL - DISCHARGE LINE THERMOSTAT
- TDR - TIME DELAY RELAY (5 SEC DELAY ON)
- TNS - TRANSFORMER
- TEMP - SENSOR, TEMPERATURE
- Y2C - HIGH CAPACITY CONTROL RELAY

⚠ WARNING

HAZARDOUS VOLTAGE!
DISCONNECT ALL ELECTRICAL POWER INCLUDING REMOTE DISCONNECTS BEFORE SERVICING.
Failure to disconnect power before servicing can cause severe personal injury or death.

⚠ CAUTION

USE COPPER CONDUCTORS ONLY!
UNIT TERMINALS ARE NOT DESIGNED TO ACCEPT OTHER TYPES OF CONDUCTORS. Failure to do so may cause damage to the equipment.

NOTES:

1. BE SURE POWER SUPPLY AGREES WITH EQUIPMENT NAMEPLATE.
2. POWER WIRING AND GROUNDING OF EQUIPMENT MUST COMPLY WITH LOCAL CODES.
3. LOW VOLTAGE WIRING TO BE NO. 18 AWG MINIMUM CONDUCTOR.
4. ODT-B MUST BE SET LOWER THAN ODT-A
5. IF ODT-B IS NOT USED, CONNECT A JUMPER WIRE FROM W3 TO W2. IF ODT-A IS NOT USED, CONNECT A JUMPER WIRE FROM W2 TO W1.
6. IF ELECTRIC HEATER DOES NOT HAVE A 3RD CONTACTOR (CH), CONNECT A JUMPER WIRE FROM W3 TO W2. IF ELECTRIC HEATER DOES NOT HAVE A 2ND CONTACTOR (BH), CONNECT A JUMPER WIRE FROM W2 TO W1.
7. X2 MUST BE CONNECTED TO VARIABLE SPEED AIR HANDLER TERMINAL W3 AS SHOWN. FOR PROPE INDOOR AIR FLOW DURING THE DEFROST CYCLE
8. BE SURE THE JUMPER BETWEEN R AND BK IS CUT OR REMOVED.
9. WITH O AND Y/Y2 ENERGIZED, INDOOR FAN IS AT 80% AIRFLOW.
10. WITH O, Y/Y2 AND BK ENERGIZED, INDOOR FAN IS AT 100% AIRFLOW.

FOR CANADIAN INSTALLATIONS
POUR INSTALLATIONS CANADIENNES

CAUTION: NOT SUITABLE FOR USE ON SYSTEMS EXCEEDING 150V-TO-GROUND
ATTENTION: NE CONVIENT PAS AUX INSTALLATIONS DE PLUS DE 150 V A LA TERRE

Dimensions

4TWX6 Outline Drawing

Note: All dimensions are in MM (Inches).

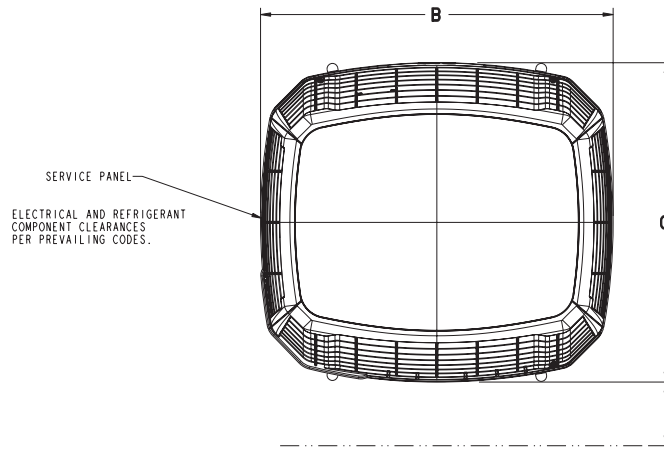

UNIT SHOULD BE PLACED SO ROOF RUN-OFF WATER DOES NOT POUR DIRECTLY ON UNIT, AND SHOULD BE AT LEAST 305 (12") FROM WALL AND ALL SURROUNDING SHRUBBERY ON TWO SIDES. OTHER TWO SIDES UNRESTRICTED.

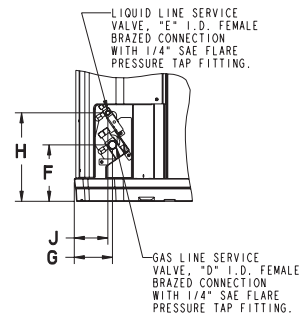
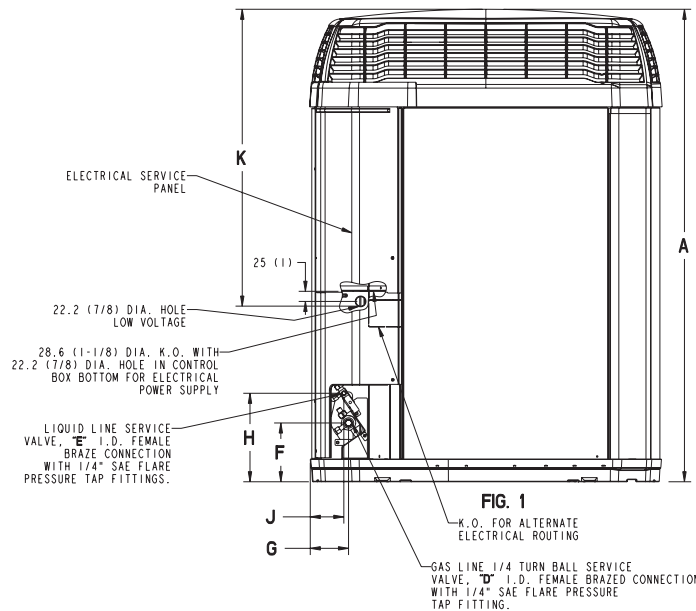

FIG. 2

MODELS	BASE	A	B	C	D	E	F	G	H	J	K
4TWX6024E	4	1267 (49-7/8)	946 (37-1/4)	870 (34-1/4)	5/8	3/8	152 (6)	98 (3-7/8)	219 (8-5/8)	86 (3-3/8)	730 (28-3/4)
4TWX6036E	4	1369 (53-7/8)	946 (37-1/4)	870 (34-1/4)	3/4	3/8	152 (6)	98 (3-7/8)	219 (8-5/8)	86 (3-3/8)	730 (28-3/4)
4TWX6048E	4	1369 (53-7/8)	946 (37-1/4)	870 (34-1/4)	7/8	3/8	152 (6)	98 (3-7/8)	219 (8-5/8)	86 (3-3/8)	730 (28-3/4)
4TWX6060E	4	1369 (53-7/8)	946 (37-1/4)	870 (34-1/4)	1-1/8	3/8	152 (6)	98 (3-7/8)	219 (8-5/8)	86 (3-3/8)	730 (28-3/4)

Mechanical Specifications

General

The 4TWX6 is fully charged from the factory for matched indoor section and up to 15 feet of piping. This unit is designed to operate at outdoor ambient temperatures as high as 115°F. Cooling capacities are matched with a wide selection of air handlers and furnace coils that are AHRI certified. The unit shall be certified to UL 1995. Exterior is designed for outdoor application.

Casing

Unit casing is constructed of heavy gauge, G60 galvanized steel and painted with a weather-resistant powder paint on all louvers and panels. Corrosion and weatherproof CMBP-G30 DuraTuff™ base.

Refrigerant Controls

Refrigeration system controls include condenser fan, compressor contactor and high pressure switch. High and low pressure controls are inherent to the compressor. A factory installed liquid line drier is standard.

Compressor

The Climatuff® 2-stage compressor features internal over temperature and pressure protection and hermetic motor. Other features include: roto lock suction and discharge refrigerant connections, centrifugal oil pump and modular plugs for electrical connections.

Condenser Coil

The outdoor coil provides low airflow resistance and efficient heat transfer. The coil is protected on all four sides by louvered panels.

Low Ambient Cooling

As manufactured, this unit has a cooling capability to 55°F. For low ambient cooling below 55° see Application Guide APP-APG013-EN.

