

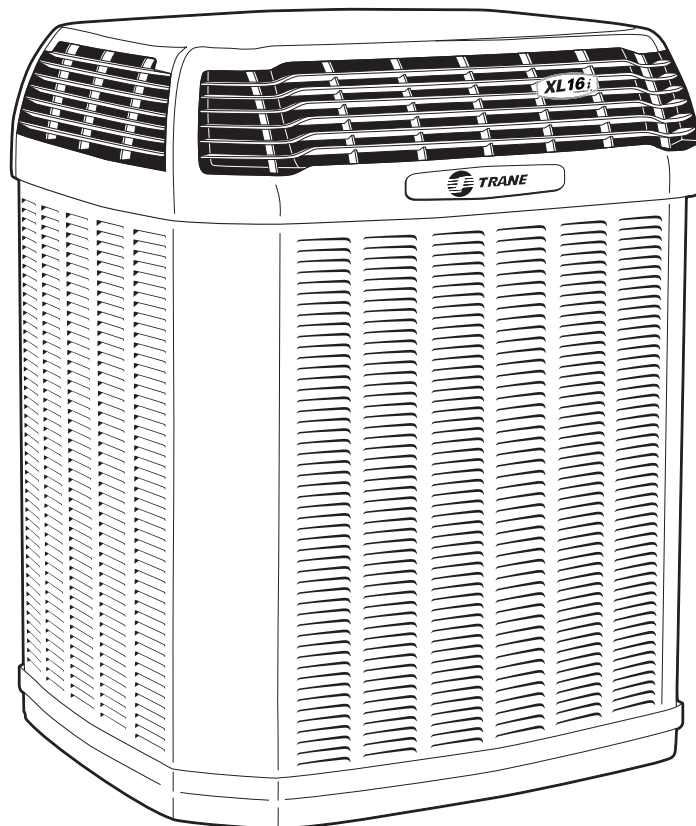

Split System Cooling Product Data

XL16i
4TTX6024, 036, 048 & 060C
with ComfortLink™ II and Charge Assist™

2, 3, 4 & 5 Tons



PUB. NO. 22-1752-07



Features and Benefits

- **CLIMATUFF™** 2-stage scroll compressor
- Efficiency up to **17.25 SEER**
- All Aluminum **SPINE FIN™** coil
- **WEATHERGUARD™ II** top shields unit
- **WEATHERGUARD™** fasteners
- **QUICK-SESS™** cabinet, service access and refrigerant connections with full coil protection
- **DURATUFF™** base, fast complete drain, weather proof
- **COMFORT "R"™** mode approved
- **COMFORTLINK™ II** System-only two wire control connection
- **CHARGE ASSIST™**- Fast/accurate charging every time
- Glossy corrosion resistant finish
- Internal compressor high/low pressure & temperature protection
- 036 ships with start kit
- 060 ships with start kit and sump heat
- Compressor sump heat
- Liquid line filter/drier
- Tarpaulin gray cabinet with anthracite gray top
- Low sound with advanced fan system and compressor sound insulator
- Variable speed fan
- XL Seacoast shield
- Service valve cover
- R-410A refrigerant
- 70 or 100% capacity modulation
- S.E.E.T. design testing
- 100% line run test
- Low ambient cooling to 55° as shipped
- **Extended warranties available**

Contents

Features and Benefits	2
General Data	4
Product Specifications	4
A-weighted Sound Power Level [dB(A)]	4
Accessory Description and Usage	5
ARI Standard Capacity Rating Conditions	5
Model Nomenclature	6
Electrical Data	7
Dimensions	10
Mechanical Specification Options	11



General Data

Product Specifications

Model No. ①	4TTX6024C1	4TTX6036C1	4TTX6048C1	4TTX6060C1
Electrical Data V/Ph/Hz ②	230/1/60	230/1/60	230/1/60	230/1/60
Min Cir Ampacity	13	24	28	35
Max Fuse Size (Amps)	20	40	45	60
Compressor	CLIMATUFF® - SCROLL	CLIMATUFF® - SCROLL	CLIMATUFF® - SCROLL	CLIMATUFF® - SCROLL
RL AMPS - LR AMPS	10.3 - 52	16.7 - 82	21.2 - 96	25.6 - 118
Outdoor Fan FL Amps	.60	2.80	1.10	2.80
Fan HP	1/15	1/3	1/5	1/3
Fan Dia (inches)	23	27.6	27.6	27.6
Coil	Spine Fin™	Spine Fin™	Spine Fin™	Spine Fin™
Refrigerant R-410A	5/9-LB/OZ	6/10-LB/OZ	7/8-LB/OZ	11/3-LB/OZ
Line Size - (in.) O.D. Gas ③	5/8	3/4	7/8	7/8
Line Size - (in.) O.D. Liquid ③	5/16	3/8	3/8	3/8
Dimensions H x W x D (Crated)	47.6 x 30.1 x 33	49.4 x 35.1 x 38.7	53.4 x 35.1 x 38.7	53.4 x 35.1 x 38.7
Weight - Shipping	256	287	310	355
Weight - Net	220	242	262	307
Start Components	NO	NO	NO	YES
Sound Enclosure	YES	YES	YES	YES
Compressor Sump Heat	NO	NO	NO	YES
Optional Accessories: ④				
Rubber Isolator Kit	BAYISLT101	BAYISLT101	BAYISLT101	BAYISLT101
Snow Leg - Base & Cap 4" High	BAYLEGS002	BAYLEGS002	BAYLEGS002	BAYLEGS002
Snow Leg - 4" Extension	BAYLEGS003	BAYLEGS003	BAYLEGS003	BAYLEGS003
Hard Start Kit Scroll	BAYKSKT260	BAYKSKT260	BAYKSKT260	
Extreme Condition Mounting Kit	BAYECMT023	BAYECMT004	BAYECMT004	BAYECMT004
Vertical Discharge Air Kit Base 4	BAYVDTA003	BAYVDTA004	BAYVDTA004	BAYVDTA004
Auto Charge Solenoid Kit	BAYCAKT001	BAYCAKT001	BAYCAKT001	BAYCAKT001
24 Volt Wiring Harness	BAYACHP024A	BAYACHP024A	BAYACHP024A	BAYACHP024A
Refrigerant Lineset ⑤	TAYREFLN6*	TAYREFLN7*	TAYREFLN3*	TAYREFLN3*

① Certified in accordance with the Air-Source Unitary Heat Pump Equipment certification program which is based on ARI Standard 210/240.

② Calculated in accordance with N.E.C. Only use HACR circuit breakers or fuses.

③ Standard line lengths - 60'. Standard lift - 25' Suction and Liquid line.

For Greater lengths and lifts refer to refrigerant piping software Pub# 32-3312-0*. (*denotes latest revision)

④ For accessory description and usage, see page 5.

⑤ * = 15, 20, 25, 30, 40 and 50 foot lineset available.

A-weighted Sound Power Level [dB(A)]

MODEL	SOUND POWER LEVEL [dB(A)]	A-WEIGHTED FULL OCTAVE SOUND POWER LEVEL dB - [dB(A)]							
		63	125	250	500	1000	2000	4000	8000
4TTX6024C1	73	42.3	53.1	57.2	68.9	63.4	61.2	51.7	44.5
4TTX6036C1	72	49.7	57.5	60.5	64.4	65	61.4	57.7	52.2
4TTX6048C1	75	52.7	54.6	60.6	71.6	68.8	61.8	59	50.4
4TTX6060C1	75	52.7	54.6	60.6	71.6	68.8	61.8	59	50.4

Note: Rated in accordance with AHRI Standard 270-2008

General Data

Accessory Description and Usage

24 Volt Wiring Harness — Used to wire a communicating outdoor unit to an existing 24 Volt indoor section.

Charge Assist™ Solenoid Kit — fast/accurate charging every time.

Rubber Isolators — 5 large rubber donuts to isolate condensing unit from transmitting energy into mounting frame or pad. Use on any application where sound transmission needs to be minimized.

Extreme Condition Mount Kit — Bracket kits to securely mount condensing unit to a frame or pad without removing any panels. Use in areas with high winds, or on commercial roof tops, etc.

Low Ambient Cooling — For low ambient cooling below 55° see Application Guide SSC-APG005-EN.

ARI Standard Capacity Rating Conditions

ARI STANDARD 210/240 RATING CONDITIONS —

- (A) Cooling 80°F DB, 67°F WB air entering indoor coil, 95°F DB air entering outdoor coil.
- (B) High Temperature Heating 47°F DB, 43°F WB air entering outdoor coil, 70°F DB air entering indoor coil.
- (C) Low Temperature Heating 17°F DB, 15°F WB air entering outdoor coil, 70°F DB air entering indoor coil.
- (D) Rated indoor airflow for heating is the same as for cooling.

ARI STANDARD 270 RATING CONDITIONS — (Noise rating numbers are determined with the unit in cooling operation.) Standard Noise Rating number is at 95°F outdoor air.



ARI Standard
210/240 UHP





Model Nomenclature

Outdoor Units

4 T T X 6 0 3 6 C 1 0 0 0 A A

- Refrigerant Type**
 - 2 = R-22
 - 4 = R-410A
- TRANE**
- Product Type**
 - W = Split Heat Pump
 - T = Split Cooling
- Product Family**
 - Z = Leadership – Two Stage
 - X = Leadership
 - R = Replacement/Retail
 - B = Basic
 - A = Light Commercial
- Family SEER**
 - 0 = 10 3 = 13 6 = 16
 - 1 = 11 4 = 14 8 = 18
 - 2 = 12 5 = 15 9 = 19
- Split System Connections 1-6 Tons**
 - 0 = Brazed
- Nominal Capacity in 000s of BTUs**
- Major Design Modifications**
- Power Supply**
 - 1 = 200-230/1/60 or 208-230/1/60
 - 3 = 200-230/3/60
 - 4 = 460/3/60
- Secondary Function**
- Minor Design Modifications**
- Unit Parts Identifier**

Gas Furnaces

T U D 2 B 0 8 0 A C V 3 2 A A

- Furnace Configuration**
 - TU = Upflow/Horizontal
 - TD = Downflow/Horizontal
- Type**
 - E = 80% Induced Draft Standard
 - D = 80% Induced Draft Premium
 - C = 90% Condensing Standard
 - X = 90% Condensing Premium
 - H = 95% Condensing Premium
- Number of Heating Stages**
 - 1 = Single Stage
 - 2 = Two Stage
 - 3 = Three Stage
- Cabinet Width**
 - A = 14.5" Cabinet Width
 - B = 17.5" Cabinet Width
 - C = 21.0" Cabinet Width
 - D = 24.5" Cabinet Width
- Heating Input**
 - 080 = 80,000 MBTUH
- Major Design Change**
- Voltage**
 - 9 = 115 Volts / 60 Hertz / Natural Gas
 - A = 115 Volts / 50 Hertz / Natural Gas
 - C = 115 Volts / Natural Gas with Communicating System Control
 - F = 115 Volts / Natural Gas with Integrated Electronic Filter
 - D = 115 Volts / Natural Gas with Communicating System Control and Integrated Electronic Filter
- Air Capacity for Cooling**
 - 36 = 3 Ton Standard PSC Motor
 - H3 = 3 Ton High Efficiency Motor
 - V3 = 3 Ton Variable Speed Motor
- Draft Inducer Speeds**
 - 1 = Single Speed
 - 2 = Two Speed
 - V = Variable Speed
- Minor Design Change**
- Service Digit - Not Orderable**

Air Handlers – Residential

4 T E E 3 C 0 5 A 1 0 0 0 A A

- Refrigerant Type**
 - 4 = R-410A
 - 2 = R-22
- Application**
 - TE = Fully Convertible
 - TG = Semi Convertible
 - TF = Front Return
 - TV = Vertical
- Product Family**
 - E = Leadership – Variable Speed
 - P = Leadership
 - C = Replacement/Retail
 - B = Basic
- Flow Control**
 - 3 = Nonbleed TXV
 - 4 = FCCV*
- Feature Identifier**
 - 0 = Standard Unit
 - F = Air-Tite™
 - D = Integrated Whole House Air Cleaner
 - C = Communicating Air Cleaner
- Model Number Distinguisher**
- Major Design Modifications**
- Power Supply**
 - 1 = Single Phase
- Electrical Connection**
 - 0 = Pig Tails
 - B = Circuit Breaker
 - D = Pull Disconnect
- Future Option – Factory Installed Heater Nominal KW Value**
- Minor Design Modifications**
- Unit Parts Identifier**

Coils – Residential

4 T X C B 0 0 1 C C 3 H C A A

- Refrigerant Type**
 - 4 - R410A
- Product Family**
 - T-Premium (Heat Pump or Convertible Coil)
- Coil Design**
 - X - Direct Expansion Evaporator Coil
- Product Family**
 - C - Cased A Coil
 - A - Uncased A Coil
 - F - Cased Horizontal Flat Coil
- Coil Width (Cased/Uncased)**
 - A - 14.5" / 13.3"
 - B - 17.5" / 16.3"
 - C - 21.0" / 19.8"
 - D - 24.5" / 23.3"
 - H - 10.5"
- Refrigerant Line Coupling**
 - 0 - Brazed
- Model Number Distinguisher**
- Major Design Change**
- Efficiency**
 - C - Standard
 - S - Hi Efficiency (Derived from 10 SEER products)
- Refrigerant Control**
 - 3 - TXV - Non-Bleed
- Coil Circuitry**
 - H - Heat Pump
- Airflow Configuration**
 - A - Upflow Only
 - U - Upflow / Downflow
 - H - Horizontal Only
 - C - Convertible - Upflow, Downflow, Left or Right Airflow
- Minor Design Change**
- Unit Parts Identifier**

NOTE: There will be a phase-in of new model numbers for new air handlers over next 2 years.
*Shipped with R-22 FCCV

Electrical Data

Schematic Diagrams

(SEE LEGEND)

4TTX6024C, 048C

4TTX6036C

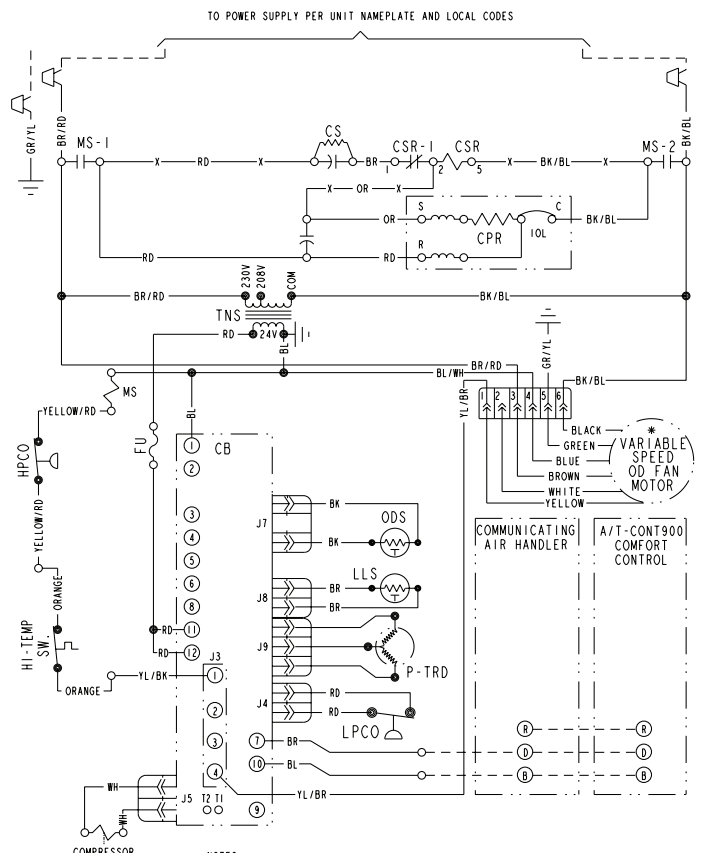
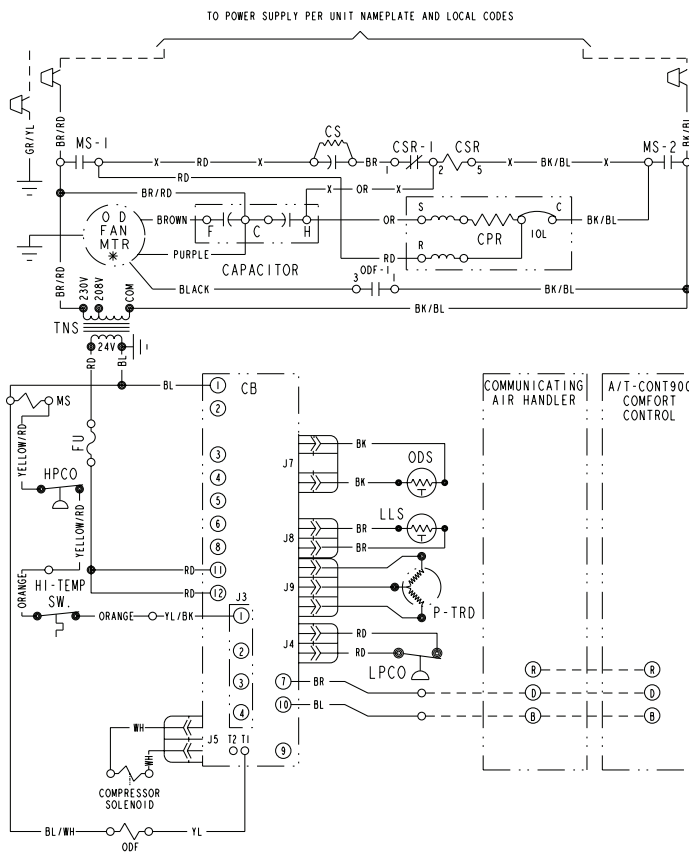

NOTES:
 1. LOW VOLTAGE (24 V.) FIELD WIRING MUST BE 18 AWG MIN.
 2. FOR 208V OPERATION, SWAP BR/RD TRANSFORMER LEAD AND INSULATED CAP ON 208V CENTER TRANSFORMER TERMINAL.

NOTES:
 1. LOW VOLTAGE (24 V.) FIELD WIRING MUST BE 18 AWG MIN.
 2. FOR 208V OPERATION, SWAP BR/RD TRANSFORMER LEAD AND INSULATED CAP ON 208V CENTER TRANSFORMER TERMINAL.

<p>⚠ WARNING HAZARDOUS VOLTAGE! DISCONNECT ALL ELECTRIC POWER INCLUDING REMOTE DISCONNECTS BEFORE SERVICING. FAILURE TO DISCONNECT POWER BEFORE SERVICING CAN CAUSE SEVERE PERSONAL INJURY OR DEATH!</p>	<p>⚠ CAUTION USE COPPER CONDUCTORS ONLY! UNIT TERMINALS ARE NOT DESIGNED TO ACCEPT OTHER TYPES OF CONDUCTORS. FAILURE TO DO SO MAY CAUSE DAMAGE TO THE EQUIPMENT!</p>
---	--

<p>⚠ WARNING HAZARDOUS VOLTAGE! DISCONNECT ALL ELECTRIC POWER INCLUDING REMOTE DISCONNECTS BEFORE SERVICING. FAILURE TO DISCONNECT POWER BEFORE SERVICING CAN CAUSE SEVERE PERSONAL INJURY OR DEATH!</p>	<p>⚠ CAUTION USE COPPER CONDUCTORS ONLY! UNIT TERMINALS ARE NOT DESIGNED TO ACCEPT OTHER TYPES OF CONDUCTORS. FAILURE TO DO SO MAY CAUSE DAMAGE TO THE EQUIPMENT!</p>
---	--

NOTE
 THREE PHASE MOTOR (S) FACTORY SUPPLIED IN THIS EQUIPMENT PROTECTED UNDER PRIMARY SINGLE-PHASE CONDITIONS.

NOTE
 THREE PHASE MOTOR (S) FACTORY SUPPLIED IN THIS EQUIPMENT PROTECTED UNDER PRIMARY SINGLE-PHASE CONDITIONS.



Electrical Data

Schematic Diagrams

(SEE LEGEND)

4TTX6060C

TO POWER SUPPLY PER UNIT NAMEPLATE AND LOCAL CODES

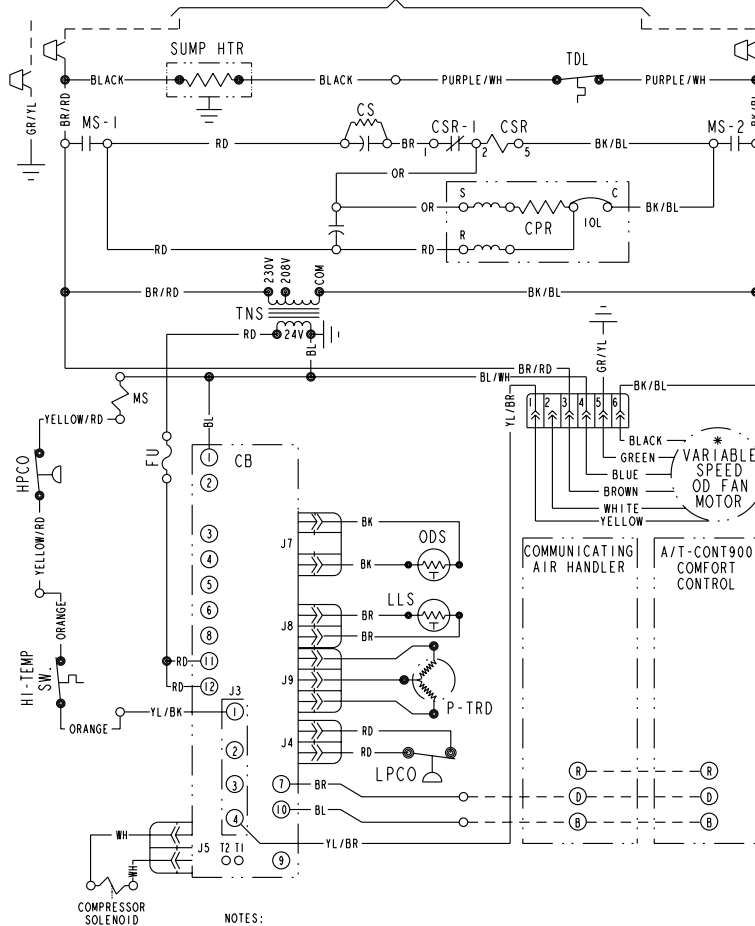

- NOTES:
1. LOW VOLTAGE (24 V.) FIELD WIRING MUST BE 18 AWG MIN.
 2. FOR 208V OPERATION, SWAP BR/RD TRANSFORMER LEAD AND INSULATED CAP ON 208V CENTER TRANSFORMER TERMINAL.



<p>⚠ WARNING HAZARDOUS VOLTAGE! DISCONNECT ALL ELECTRIC POWER INCLUDING REMOTE DISCONNECTS BEFORE SERVICING. FAILURE TO DISCONNECT POWER BEFORE SERVICING CAN CAUSE SEVERE PERSONAL INJURY OR DEATH!</p>	<p>⚠ CAUTION USE COPPER CONDUCTORS ONLY! UNIT TERMINALS ARE NOT DESIGNED TO ACCEPT OTHER TYPES OF CONDUCTORS. FAILURE TO DO SO MAY CAUSE DAMAGE TO THE EQUIPMENT!</p>
---	--

NOTE
THREE PHASE MOTOR (S) FACTORY SUPPLIED IN THIS EQUIPMENT PROTECTED UNDER PRIMARY SINGLE-PHASE CONDITIONS.





















Electrical Data

Schematic Diagrams

LEGEND

	COLOR OF WIRE				
BK/BL	BLACK WIRE WITH BLUE MARKER				
	COLOR OF MARKER				
BK	BLACK	OR	ORANGE	YL	YELLOW
BL	BLUE	RD	RED	GR	GREEN
BR	BROWN	WH	WHITE	PR	PURPLE

SYMBOLS

	24 V.	}	FACTORY WIRING
	LINE V.		
	24 V.	}	FIELD WIRING
	LINE V.		
	FIELD INSTALLED FACTORY WIRING		
	GROUND		
	JUNCTION		
	WIRE NUT OR CONNECTOR		
	COIL		
	CAPACITOR		
	RELAY CONTACT (N.O.)		
	RELAY CONTACT (N.C.)		
	THERMISTOR		
	INTERNAL OVERLOAD PROTECTOR		
	PRESSURE ACTUATED SWITCH		
	TEMP. ACTUATED SWITCH		
	POL. PLUG FEMALE HOUSING (MALE TERM.)		
	POL. PLUG MALE HOUSING (FEMALE TERM.)		
	RESISTOR OR HEATING ELEMENT		
	MOTOR WINDING		
	TERMINAL		

CA	COOLING ANTICIPATOR	LPCO	LOW PRESSURE CUTOFF SW.
CBS	COIL BOTTOM SENSOR	MS	COMPRESSOR MOTOR CONTACTOR
CF	FAN CAPACITOR	ODA	OUTDOOR ANTICIPATOR
CN	WIRE CONNECTOR	OFT	OUTDOOR FAN THERMOSTAT
CPR	COMPRESSOR	ODS	OUTDOOR TEMPERATURE SENSOR
CR	RUN CAPACITOR	ODT	OUTDOOR THERMOSTAT
CS	STARTING CAPACITOR	RHS	RESISTANCE HEAT SWITCH
CSR	CAPACITOR SWITCHING RELAY	SC	SWITCHOVER VALVE SOLENOID
DFC	DEFROST CONTROL	SM	SYSTEM "ON-OFF" SWITCH
F	INDOOR FAN RELAY	TDL	DISCHARGE LINE THERMOSTAT
HA	HEATING ANTICIPATOR	TNS	TRANSFORMER
HPCO	HIGH PRESSURE CUTOFF SW.	TS	HEATING-COOLING THERMOSTAT
IOL	INTERNAL OVERLOAD PROTECTOR	TSH	HEATING THERMOSTAT

Dimensions

4TTX6 Outline Drawing

Note: All dimensions are in MM (Inches).

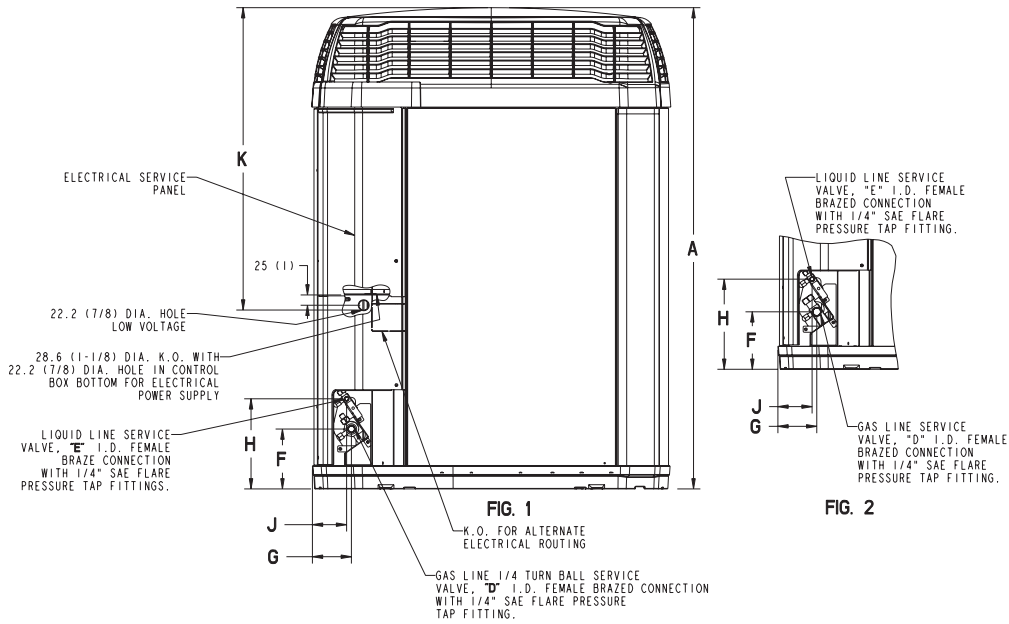
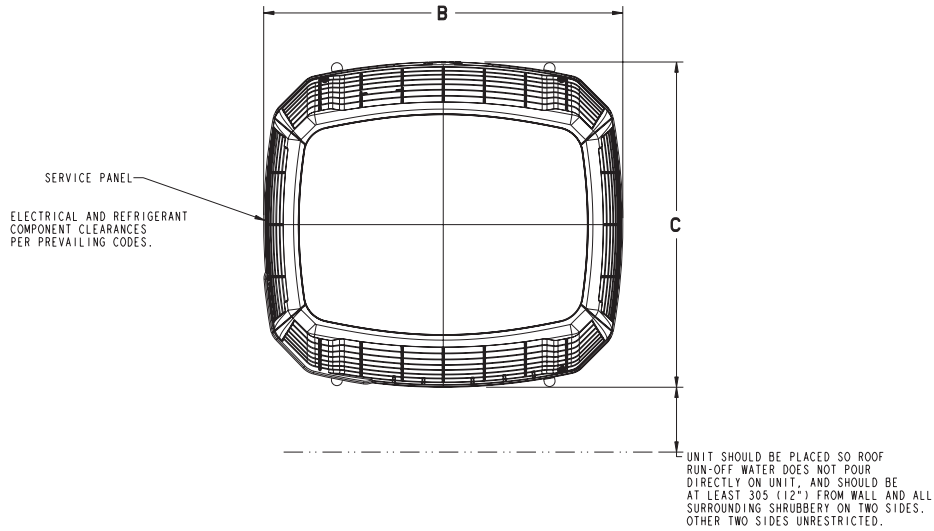

MODELS	BASE	A	B	C	D	E	F	G	H	J	K
4TTX6024C	3	1118 (44)	829 (32-5/8)	756 (29-3/4)	5/8	5/16	143 (5-5/8)	92 (3-5/8)	210 (8-1/4)	79 (3-1/8)	692 (27-1/4)
4TTX6036C	4	1064 (41-7/8)	946 (37-1/4)	870 (34-1/4)	3/4	3/8	152 (6)	98 (3-7/8)	219 (8-5/8)	86 (3-3/8)	730 (28-3/4)
4TTX6048C 4TTX6060C	4	1267 (49-7/8)	946 (37-1/4)	870 (34-1/4)	7/8	3/8	152 (6)	98 (3-7/8)	219 (8-5/8)	86 (3-3/8)	730 (28-3/4)

From Dwg. D152635 Rev. 15

Mechanical Specification Options

General

The 4TTX6 is fully charged from the factory for matched indoor section and up to 15 feet of piping. This unit is designed to operate at outdoor ambient temperatures as high as 115°F. Cooling capacities are matched with a wide selection of air handlers and furnace coils that are A.R.I. certified. The unit is certified to UL 1995. Exterior is designed for outdoor application.

ComfortLink™ II

This outdoor unit contains the ComfortLink™ II digital communication with 2 wire connection to outdoor and Plug-n-Play set up.

Charge Assist™

The Charge Assist™ indicates system Charge Status.

Casing

Unit casing is constructed of heavy gauge, G60 galvanized steel and painted with a weather-resistant powder paint on all louvers, panels, prepaint on all other panels. Corrosion and weather-proof CMBP-G30 DuraTuff™ base.

Refrigerant Controls

Refrigeration system controls include condenser fan, compressor contactor and high pressure switch. High and low pressure controls are inherent to the compressor. A factory installed liquid line drier is standard.

Compressor

The Climatuff® 2-stage compressor features internal over temperature and pressure protection and total dipped hermetic motor. Other features include: roto lock suction and discharge refrigerant connections, centrifugal oil pump and low vibration and noise.

Condenser Coil

The outdoor coil provides low airflow resistance and efficient heat transfer. The coil is protected on all four sides by louvered panels.

Low Ambient Cooling

As manufactured, this unit has a cooling capability to 55°F. For low ambient cooling below 55° see Application Guide SSC-APG005-EN.

Comfort Control

ComfortLink™ II Control with Plug-n-Play set up and 3 wire connection.



**ARI Standard
210/240 UAC**





Trane
www.trane.com

03/10

Trane has a policy of continuous product and product data improvement and it reserves the right to change design and specifications without notice.